

▶主要諸元 (型式：7200G-2)

仕様		7200	
		クレーン	ラフティングタワー
最大つり上げ能力	t×m	200×5.0	25×18.0
ブーム(タワー)長さ	m	18.3~73.2	36.6~64.1
		37.5×14.4 (ロング)	
タワージブ長さ	m	—	27.4~51.8
最大タワー+タワージブ長さ	m	—	64.1+51.8
ロープ速度	主巻 巻上巻下 m/min	110~3	110~3
	補巻 巻上巻下 m/min	110~3	—
	タワージブ起伏 巻上巻下 m/min	—	60~3
	ブーム(タワー)起伏 巻上巻下 m/min	(26~2)×2	
回転速度	min ⁻¹ {rpm}	2.2{2.2}	
走行速度	km/h	1.0/0.6	
作業時質量(基本姿勢)	t	215	226
接地圧	kPa{kgf/cm ² }	125{1.27}	131{1.34}
登坂能力(tanθ)	%(度)	30(16.7)	—
定格ラインプル	kN{tf}	1本掛132{13.5}/ 多本掛123{12.5}	
エンジン	名称	日野P11C-VN	
	定格出力	kW/min ⁻¹ 271/1,850	
ワイヤロープ	主巻	mm	φ28
	補巻	mm	φ28
	ブーム(タワー)	mm	φ22
	ジブ(タワージブ)	mm	— φ22

登坂能力は最大登坂時の傾斜角度であり、地盤の状態やクレーンによってはこの数値より低くなります。

各速度は軽負荷の時の値であり、負荷により速度の変動があります。

各ロープ速度はドラム1層目での値です。

単位は国際単位系のSI単位で、{}内は従来表示です。

▶仕様とアタッチメント

仕様		7200	
		クレーン	ラフティングタワー
アタッチメント			
6.1m上部ブーム		◎	—
4.6m中間テーパーブーム*1		◎	—
1.58mタワーキャップ		—	◎
7.6m下部ブーム(共用)		◎	
3.0m中間ブーム(ケーブルローラ付・共用)		○	
6.1m中間ブーム(ケーブルローラ付・共用)		○	
9.1m中間ブーム(ケーブルローラ付・共用)		○	◎
9.1mタワー専用中間ブーム*2		○兼用可	◎
9.1m上部タワージブ*3		△	◎
9.1m下部タワージブ		—	◎
3.0m中継ジブ*4		△	◎
3.0m中間タワージブ*5		△	○
6.1m中間タワージブ*5		△	◎
9.1m中間タワージブ*5		△	○
200tフック(8枚シーブ)		◎	—
150tフック(100t兼用、6枚シーブ)		○	—
100tフック(4枚シーブ)		○	—
65tフック(3枚シーブ)		○	—
35tフック(1枚シーブ)		○	◎
ボールフック		○	
補助シーブ		○	—
主巻ワイヤロープ(φ28×390m)		◎	—
補巻ワイヤロープ(φ28×220m)		○	—
ブーム起伏ワイヤロープ(φ22×315m)		◎	—
タワー主巻ワイヤロープ(φ28×390m)		—	◎
タワージブ起伏ワイヤロープ(φ22×185m)		—	◎
タワーブーム起伏ワイヤロープ(φ22×315m)		—	◎

◎印は基本仕様、○印は選択可能なアタッチメントを示します。

△はロングブームを構成する場合に必要となるアタッチメントを示します。

*1 クローラクレーンの上部ブームまたはロングブームの3.0m中継ジブとセットで使用します。

*2 クローラクレーンの中間ブームに転用できます。

*3 ロングブーム仕様では上部ブームとして使用します。

*4 ロングブーム仕様では4.6mテーパーブームと、ラフティングタワーでは下部タワージブとセットで使用します。

*5 ロングブーム仕様で中間ブームとして使用します。

200t

KOBELCO 7200G-2
クローラクレーン

yonehara

クローラクレーン

▶全体図(単位: mm)

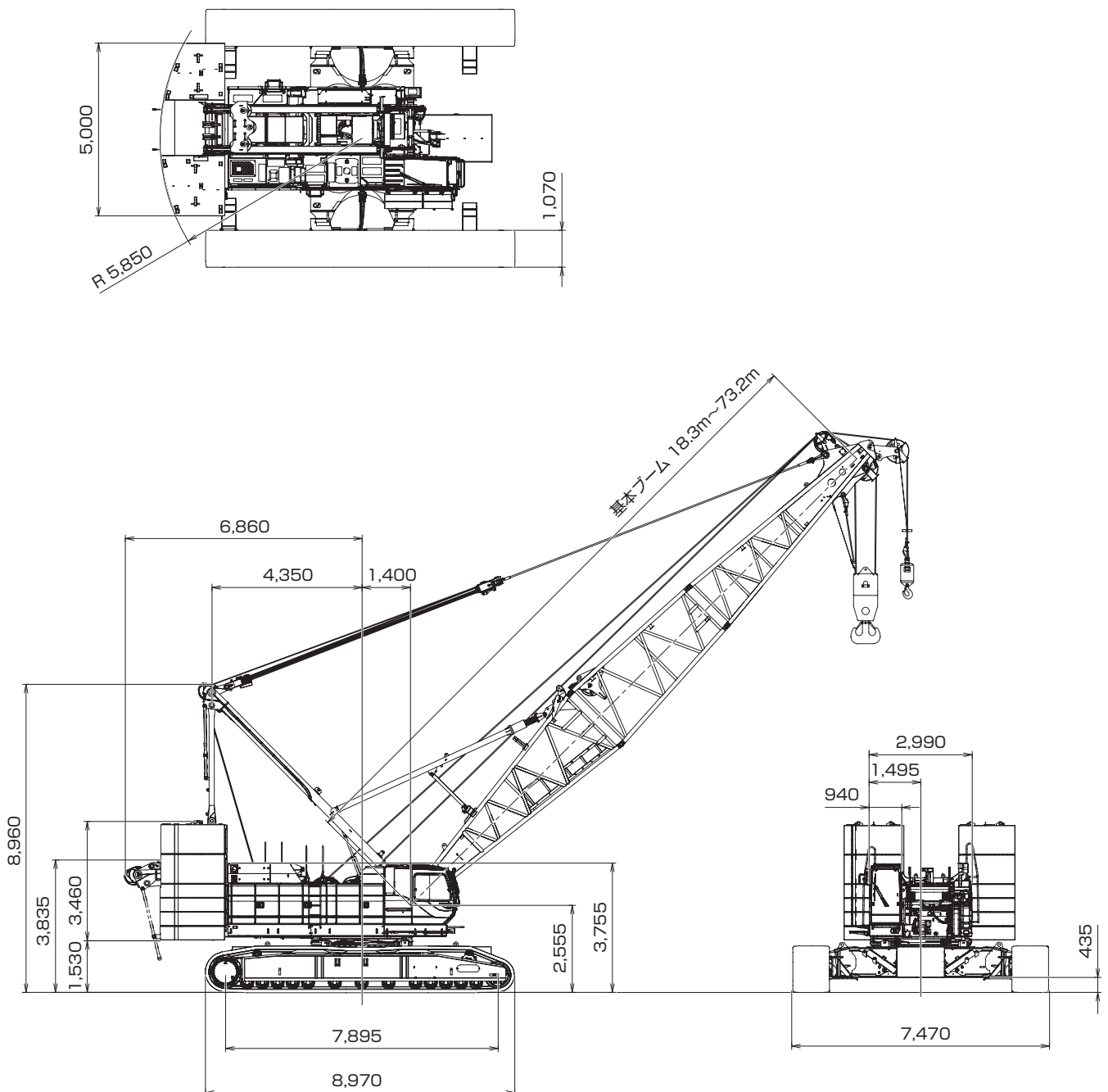

▶ブーム構成

▣ブーム構成 (9.1A中間ブーム不使用時)

- ※印は、これより短いブームの組立可能な構成を示します。
- 使用するガイラインの径はφ38mmです。

中間ブームの種類		
記号	ブーム長さ	備考
3.0	3.0m	ブーム
6.1	6.1m	ブーム
9.1	9.1m	ブーム
9.1A	9.1m	タワー専用ブーム (クレーンに兼用可能)
4.6T	4.6m	テーパーブーム
3.0A	3.0m	中継ジブ
3.0	3.0m	タワージブ
6.1	6.1m	タワージブ
9.1	9.1m	タワージブ

ブーム長さ m (ft.)	ブーム構成 (9.1A中間ブーム不使用時)	ブーム長さ m (ft.)	ブーム構成 (9.1A中間ブーム不使用時)
18.3 (60)		48.8 (160)	*
21.3 (70)	*		
24.4 (80)	*	51.8 (170)	*
27.4 (90)	*	54.9 (180)	*
30.5 (100)	*	57.9 (190)	*
33.5 (110)	*	61.0 (200)	*
36.6 (120)	*	64.0 (210)	*
39.6 (130)	*	67.1 (220)	*
42.7 (140)	*	70.1 (230)	*
45.7 (150)	*	73.2 (240)	*

▶ブーム構成 (9.1A中間ブーム使用時)

- ※印は、これより短いブームの組立可能な構成を示します。
- 使用するガイラインの径はφ38mmです。
- 9.1Aはタワー用ですがクレーンにも転用できます。

ブーム長さ m (ft.)	ブーム構成 (9.1A中間ブーム使用時)	ブーム長さ m (ft.)	ブーム構成 (9.1A中間ブーム使用時)
27.4 (90)		51.8 (170)	※
30.5 (100)		54.9 (180)	※
33.5 (110)	※ 	57.9 (190)	※
36.6 (120)	※ 	61.0 (200)	※
39.6 (130)	※ 	64.0 (210)	※
42.7 (140)	※ 	67.1 (220)	※
45.7 (150)	※ 	70.1 (230)	※
48.8 (160)	※ 	73.2 (240)	※

▶ロングブーム構成

- ※印は、これより短いブームの組立可能な構成を示します。
 - 使用するガイラインの径はφ38mmです。
 - 9.1Aはタワー用ですがクレーンにも転用できます。
- 9.1Aを使用する場合は、右図のように組み替えてください。

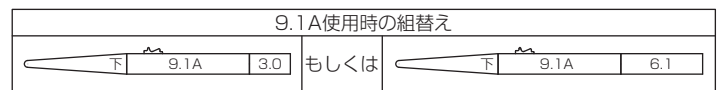

ブーム長さ m (ft.)	ブーム構成/ロング
73.2 (240)	
76.2 (250)	※
79.2 (260)	 ※
82.3 (270)	 ※
85.3 (280)	
88.4 (290)	
91.4 (300)	

▶作動範囲図

■主ブーム

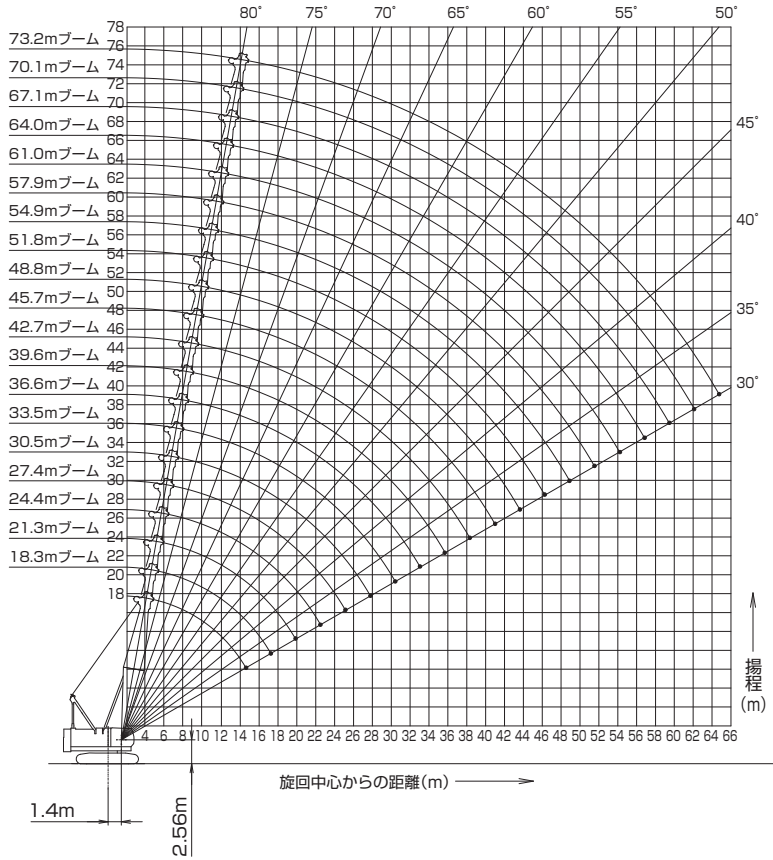

■ロングブーム

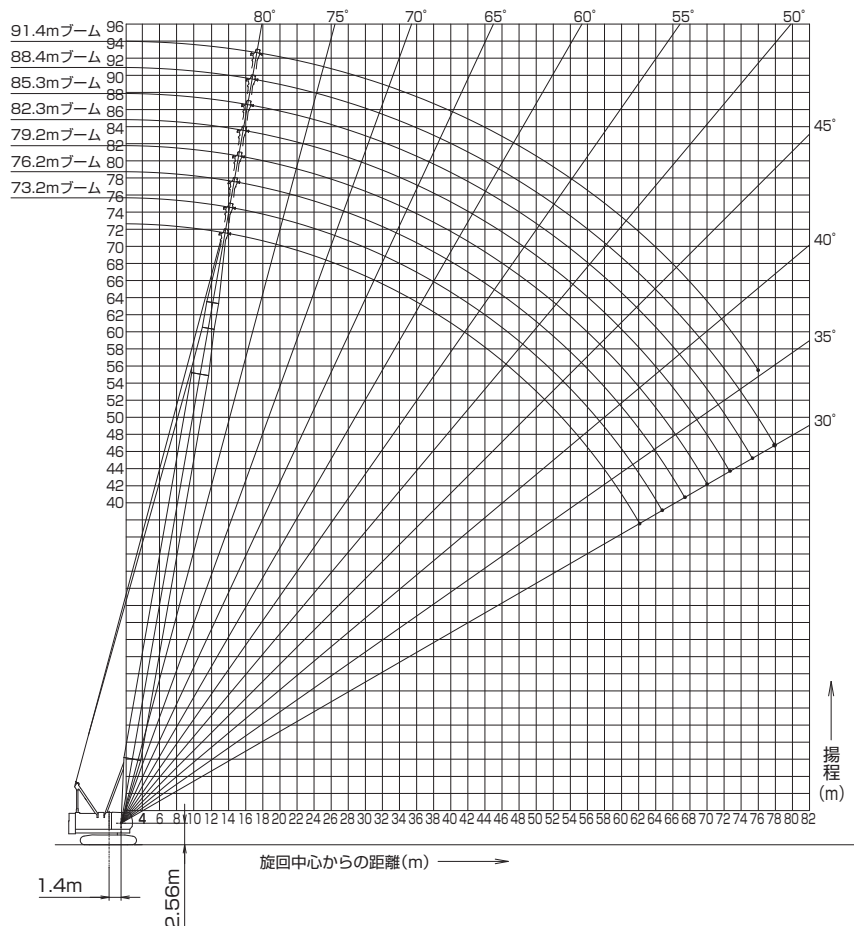

フック巻上限界 (単位:m)

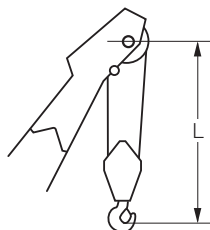

使用フック	L
200tフック	5.2
150tフック	5.8
100tフック	5.2
65tフック	5.0
35tフック	5.0

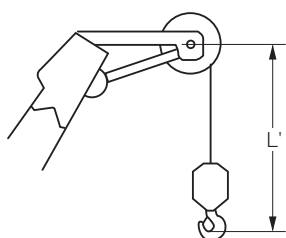

使用フック	L'
ボールフック	5.0

定格総荷重

- 定格総荷重とは、水平堅土上における転倒荷重の78%以内で、フックブロック、玉掛用ワイヤロープ等のつり具の質量を含んだ値です。
- 作業半径とはクレーン旋回中心よりつり上荷重の重心までの水平距離を意味します。
- 実際につり上げ得る荷重は定格総荷重から（フック+玉掛用ワイヤロープ等のつり具）の質量を差し引いた値になります。
- 定格総荷重をつる場合にも風の影響、地盤の状態、作業速度その他安全作業に有害な状況がある時はオペレータは荷重の軽減、作業速度を遅くするなど状況に応じた判断をする責任があります。
- 表中の空欄の箇所では作業を行うことができません。
- 巻上げロープ巻掛本数に対する最大巻上荷重とフックの質量
- クレーン作業中には必ずガントリを最高位置に立ててください。
- すべてのブーム長さにおける中間ブームの構成は取扱説明書の指示を厳守してください。
- 主ブームに補助シーブを取り付けたままで主フックを使用する場合の定格総荷重は、主ブーム定格総荷重から、一律0.9t差し引いた値となります。ただし最小定格総荷重は2.4tとします。
- 補助シーブを装着できる主ブーム長さは、18.3m (60) ~ 73.2m (240)、ロングブーム長さは、73.2m (240) ~ 88.4m (290) です。
- △ 操作ミスなどによるつり荷の落下を防ぐため、クレーン作業では自由降下（フリーフォール）作業は行わないでください。

フック呼称	最大巻上荷重 (t)												フック質量
	1本掛	2本掛	3本掛	4本掛	5本掛	6本掛	7本掛	8本掛	10本掛	12本掛	14本掛	16本掛	
200t	-	-	-	-	-	-	-	-	125.0	150.0	175.0	200.0	2.8t
150t	-	-	-	-	-	-	-	100.0	125.0	150.0	-	-	2.3t
100t	-	-	-	-	62.5	75.0	87.5	100.0	-	-	-	-	1.8t
65t	-	25.0	37.5	50.0	62.5	65.0	-	-	-	-	-	-	1.2t
35t	13.5	25.0	35.0	-	-	-	-	-	-	-	-	-	0.9t
13.5t (ボールフック)	13.5	-	-	-	-	-	-	-	-	-	-	-	0.45t

ただし、中間ブームにブームネスティングローラ（オプション）が取付いた状態で作業する場合の定格総荷重の最大値は、使用するフックの呼称容量から使用するフック質量とブームネスティングローラ質量（右表）を差し引いた値とします。

【カウンタウエイト減量時】（オプション）

- 自立可能な最長主ブーム長さは、カウンタウエイト段数が5段（最上段から1段減量）で73.2mです。
- 補助シーブを装着できる主ブーム長さはカウンタウエイト段数が5段（最上段から1段減量）で18.3m~73.2mです。

主ブーム

ブーム長さ(m)	18.3	21.3	24.4	27.4	30.5	33.5	36.6	39.6	42.7	45.7
差し引く値(t)	0.0	0.0	0.1	0.1	0.1	0.1	0.1	0.1	0.1	0.2

ブーム長さ(m)	48.8	51.8	54.9	57.9	61.0	64.0	67.1	70.1	73.2
差し引く値(t)	0.2	0.2	0.2	0.2	0.2	0.2	0.2	0.2	0.2

ロング主ブーム

ブーム長さ(m)	73.2	76.2	79.2	82.3	85.3	88.4	91.4
差し引く値(t)	0.2	0.2	0.2	0.2	0.2	0.2	0.2

主ブーム定格総荷重表

(単位:t)

ブーム長さ 作業半径(m)	18.3	21.3	24.4	27.4	30.5	33.5	36.6	39.6	42.7	45.7	ブーム長さ 作業半径(m)
5.0	200.0/5.0m	175.0/5.5m									5.0
6.0	189.6	175.0	150.0/6.0m	150.0/6.6m							6.0
7.0	163.9	163.5	150.0	150.0	125.0/7.1m	125.0/7.6m					7.0
8.0	144.3	143.9	143.5	143.3	125.0	125.0	100.0/8.2m	100.0/8.7m			8.0
9.0	128.8	128.4	128.0	127.8	125.0	123.1	100.0	100.0	98.8/9.2m	87.5/9.7m	9.0
10.0	116.3	115.8	115.5	115.2	114.8	114.6	100.0	100.0	96.7	87.5	10.0
12.0	90.6	90.4	90.2	90.0	89.8	89.6	89.6	89.4	89.2	85.3	12.0
14.0	73.0	72.7	72.5	72.3	72.1	71.9	71.8	71.6	71.4	71.3	14.0
16.0	61.0	60.7	60.4	60.2	60.0	59.8	59.7	59.4	59.2	59.1	16.0
18.0	52.9/17.4m	51.9	51.6	51.4	51.2	50.9	50.8	50.5	50.3	50.2	18.0
20.0		45.3	45.0	44.7	44.5	44.2	44.1	43.8	43.6	43.4	20.0
22.0		45.1/20.1m	39.7	39.5	39.2	39.0	38.8	38.5	38.3	38.1	22.0
24.0			38.2/22.7m	35.3	35.0	34.7	34.6	34.3	34.0	33.9	24.0
26.0				32.9/25.4m	31.5	31.2	31.1	30.8	30.5	30.3	26.0
28.0					28.6/28.0m	28.3	28.2	27.8	27.6	27.4	28.0
30.0						25.9	25.7	25.4	25.1	24.9	30.0
32.0						25.2/30.6m	23.6	23.2	23.0	22.8	32.0
34.0							22.4/33.3m	21.4	21.1	20.9	34.0
36.0								19.9/35.9m	19.5	19.3	36.0
38.0									18.1	17.9	38.0
40.0									17.8/38.6m	16.6	40.0
42.0										15.9/41.2m	42.0

※表中の太線で囲まれた部分は、ブーム等の強度によって定められた値です。

(単位:t)

ブーム長さ 作業半径(m)	48.8	51.8	54.9	57.9	61.0	64.0	67.1	70.1	73.2	ブーム長さ 作業半径(m)
10.0	75.0/10.3m	75.0/10.8m	71.6/11.3m	62.5/11.9m						10.0
12.0	75.0	75.0	70.5	62.5	61.0/12.4m	50.0/12.9m	50.0/13.4m			12.0
14.0	71.1	70.7	66.6	61.9	58.3	50.0	50.0	47.5/14.0m	37.5/14.5m	14.0
16.0	58.9	58.7	58.4	58.3	54.9	50.0	47.7	44.8	37.5	16.0
18.0	50.0	49.8	49.5	49.5	49.2	48.1	45.1	42.3	37.5	18.0
20.0	43.2	43.0	42.8	42.7	42.4	42.3	42.2	40.3	35.2	20.0
22.0	37.9	37.7	37.5	37.3	37.1	37.0	36.8	36.5	33.2	22.0
24.0	33.6	33.4	33.2	33.0	32.8	32.7	32.4	32.2	31.3	24.0
26.0	30.1	29.9	29.6	29.5	29.2	29.1	28.9	28.6	28.5	26.0
28.0	27.2	26.9	26.7	26.5	26.3	26.2	25.9	25.6	25.6	28.0
30.0	24.7	24.4	24.2	24.0	23.7	23.6	23.3	23.1	23.0	30.0
32.0	22.5	22.3	22.0	21.8	21.6	21.5	21.2	20.9	20.9	32.0
34.0	20.7	20.4	20.2	19.9	19.7	19.6	19.3	19.0	19.0	34.0
36.0	19.0	18.8	18.5	18.3	18.1	17.9	17.6	17.4	17.3	36.0
38.0	17.6	17.3	17.1	16.9	16.6	16.5	16.2	15.9	15.8	38.0
40.0	16.3	16.1	15.8	15.6	15.3	15.2	14.9	14.6	14.5	40.0
42.0	15.2	14.9	14.6	14.4	14.2	14.0	13.7	13.5	13.4	42.0
44.0	14.3/43.8m	13.9	13.6	13.4	13.1	13.0	12.7	12.4	12.3	44.0
46.0		13.0	12.7	12.4	12.2	12.0	11.7	11.5	11.4	46.0
48.0		12.8/46.5m	11.9	11.6	11.3	11.2	10.9	10.6	10.5	48.0
50.0			11.5/49.1m	10.8	10.6	10.4	10.1	9.8	9.7	50.0
52.0				10.2/51.8m	9.9	9.7	9.4	9.1	9.0	52.0
54.0					9.2	9.0	8.7	8.4	8.3	54.0
56.0					9.1/54.4m	8.4	8.1	7.8	7.7	56.0
58.0						8.2/57.0m	7.6	7.3	7.1	58.0
60.0							7.1/59.7m	6.7	6.4	60.0
62.0								6.1	5.9	62.0
64.0								6.0/62.3m	5.3	64.0
66.0									5.1/65.0m	66.0

※表中の太線で囲まれた部分は、ブーム等の強度によって定められた値です。

▶ 補助シーブ定格総荷重表 (200tフック装着)

(単位:t)

ブーム長さ 作業半径 (m)	18.3	21.3	24.4	27.4	30.5	33.5	36.6	39.6	42.7	45.7	ブーム長さ 作業半径 (m)
5.0	13.5/5.7m										5.0
6.0	13.5	13.5/6.3m	13.5/6.8m								6.0
7.0	13.5	13.5	13.5	13.5/7.3m	13.5/7.8m						7.0
8.0	13.5	13.5	13.5	13.5	13.5	13.5/8.4m	13.5/8.9m				8.0
9.0	13.5	13.5	13.5	13.5	13.5	13.5	13.5	13.5/9.4m			9.0
10.0	13.5	13.5	13.5	13.5	13.5	13.5	13.5	13.5	13.5	13.5/10.5m	10.0
12.0	13.5	13.5	13.5	13.5	13.5	13.5	13.5	13.5	13.5	13.5	12.0
14.0	13.5	13.5	13.5	13.5	13.5	13.5	13.5	13.5	13.5	13.5	14.0
16.0	13.5	13.5	13.5	13.5	13.5	13.5	13.5	13.5	13.5	13.5	16.0
18.0	13.5	13.5	13.5	13.5	13.5	13.5	13.5	13.5	13.5	13.5	18.0
20.0	13.5/18.7m	13.5	13.5	13.5	13.5	13.5	13.5	13.5	13.5	13.5	20.0
22.0		13.5/21.4m	13.5	13.5	13.5	13.5	13.5	13.5	13.5	13.5	22.0
24.0			13.5	13.5	13.5	13.5	13.5	13.5	13.5	13.5	24.0
26.0				13.5	13.5	13.5	13.5	13.5	13.5	13.5	26.0
28.0				13.5/26.7m	13.5	13.5	13.5	13.5	13.5	13.5	28.0
30.0					13.5/29.3m	13.5	13.5	13.5	13.5	13.5	30.0
32.0						13.5	13.5	13.5	13.5	13.5	32.0
34.0							13.5	13.5	13.5	13.5	34.0
36.0							13.5/34.6m	13.5	13.5	13.5	36.0
38.0								13.5/37.2m	13.5	13.5	38.0
40.0									13.5/39.9m	13.5	40.0
42.0										12.2	42.0
44.0										11.9/42.5m	44.0

※表中の太線で囲まれた部分は、ブーム等の強度によって定められた値です。

(単位:t)

ブーム長さ 作業半径 (m)	48.8	51.8	54.9	57.9	61.0	64.0	67.1	70.1	73.2	ブーム長さ 作業半径 (m)
10.0	13.5/11.0m									10.0
12.0	13.5	13.5/11.5m	13.5/12.1m	13.5/12.6m	13.5/13.1m	13.5/13.7m				12.0
14.0	13.5	13.5	13.5	13.5	13.5	13.5	13.5/14.2m	13.5/14.7m	13.5/15.3m	14.0
16.0	13.5	13.5	13.5	13.5	13.5	13.5	13.5	13.5	13.5	16.0
18.0	13.5	13.5	13.5	13.5	13.5	13.5	13.5	13.5	13.5	18.0
20.0	13.5	13.5	13.5	13.5	13.5	13.5	13.5	13.5	13.5	20.0
22.0	13.5	13.5	13.5	13.5	13.5	13.5	13.5	13.5	13.5	22.0
24.0	13.5	13.5	13.5	13.5	13.5	13.5	13.5	13.5	13.5	24.0
26.0	13.5	13.5	13.5	13.5	13.5	13.5	13.5	13.5	13.5	26.0
28.0	13.5	13.5	13.5	13.5	13.5	13.5	13.5	13.5	13.5	28.0
30.0	13.5	13.5	13.5	13.5	13.5	13.5	13.5	13.5	13.5	30.0
32.0	13.5	13.5	13.5	13.5	13.5	13.5	13.5	13.5	13.5	32.0
34.0	13.5	13.5	13.5	13.5	13.5	13.5	13.5	13.5	13.5	34.0
36.0	13.5	13.5	13.5	13.5	13.5	13.5	13.5	13.5	13.5	36.0
38.0	13.5	13.5	13.5	13.5	13.5	13.4	13.1	12.8	12.7	38.0
40.0	13.2	13.0	12.7	12.5	12.2	12.1	11.8	11.5	11.4	40.0
42.0	12.1	11.8	11.5	11.3	11.1	10.9	10.6	10.4	10.3	42.0
44.0	11.0	10.8	10.5	10.3	10.0	9.9	9.6	9.3	9.2	44.0
46.0	10.4/45.1m	9.9	9.6	9.3	9.1	8.9	8.6	8.4	8.3	46.0
48.0		9.1/47.8m	8.8	8.5	8.2	8.1	7.8	7.5	7.4	48.0
50.0			8.0	7.7	7.5	7.3	7.0	6.7	6.6	50.0
52.0			7.8/50.4m	6.9	6.8	6.6	6.3	6.0	5.9	52.0
54.0				6.5/53.1m	6.1	5.9	5.6	5.3	5.2	54.0
56.0					5.5/55.7m	5.3	5.0	4.7	4.6	56.0
58.0						4.7	4.5	4.2	4.0	58.0
60.0						4.6/58.3m	4.0	3.6	3.3	60.0
62.0							3.8/61.0m	3.0	2.8	62.0
64.0								2.5/63.6m		64.0

※表中の太線で囲まれた部分は、ブーム等の強度によって定められた値です。

▶ 補助シーブ定格総荷重表 (150tフック装着)

(単位:t)

ブーム長さ 作業半径(m)	18.3	21.3	24.4	27.4	30.5	33.5	36.6	39.6	42.7	45.7	ブーム長さ 作業半径(m)
5.0	13.5/5.7m										5.0
6.0	13.5	13.5/6.3m	13.5/6.8m								6.0
7.0	13.5	13.5	13.5	13.5/7.3m	13.5/7.8m						7.0
8.0	13.5	13.5	13.5	13.5	13.5	13.5/8.4m	13.5/8.9m				8.0
9.0	13.5	13.5	13.5	13.5	13.5	13.5	13.5	13.5/9.4m			9.0
10.0	13.5	13.5	13.5	13.5	13.5	13.5	13.5	13.5	13.5	13.5/10.5m	10.0
12.0	13.5	13.5	13.5	13.5	13.5	13.5	13.5	13.5	13.5	13.5	12.0
14.0	13.5	13.5	13.5	13.5	13.5	13.5	13.5	13.5	13.5	13.5	14.0
16.0	13.5	13.5	13.5	13.5	13.5	13.5	13.5	13.5	13.5	13.5	16.0
18.0	13.5	13.5	13.5	13.5	13.5	13.5	13.5	13.5	13.5	13.5	18.0
20.0	13.5/18.7m	13.5	13.5	13.5	13.5	13.5	13.5	13.5	13.5	13.5	20.0
22.0		13.5/21.4m	13.5	13.5	13.5	13.5	13.5	13.5	13.5	13.5	22.0
24.0			13.5	13.5	13.5	13.5	13.5	13.5	13.5	13.5	24.0
26.0				13.5	13.5	13.5	13.5	13.5	13.5	13.5	26.0
28.0				13.5/26.7m	13.5	13.5	13.5	13.5	13.5	13.5	28.0
30.0					13.5/29.3m	13.5	13.5	13.5	13.5	13.5	30.0
32.0						13.5	13.5	13.5	13.5	13.5	32.0
34.0							13.5	13.5	13.5	13.5	34.0
36.0							13.5/34.6m	13.5	13.5	13.5	36.0
38.0								13.5/37.2m	13.5	13.5	38.0
40.0									13.5/39.9m	13.5	40.0
42.0										12.7	42.0
44.0										12.4/42.5m	44.0

※表中の太線で囲まれた部分は、ブーム等の強度によって定められた値です。

(単位:t)

ブーム長さ 作業半径(m)	48.8	51.8	54.9	57.9	61.0	64.0	67.1	70.1	73.2	ブーム長さ 作業半径(m)
10.0	13.5/11.0m									10.0
12.0	13.5	13.5/11.5m	13.5/12.1m	13.5/12.6m	13.5/13.1m	13.5/13.7m				12.0
14.0	13.5	13.5	13.5	13.5	13.5	13.5	13.5/14.2m	13.5/14.7m	13.5/15.3m	14.0
16.0	13.5	13.5	13.5	13.5	13.5	13.5	13.5	13.5	13.5	16.0
18.0	13.5	13.5	13.5	13.5	13.5	13.5	13.5	13.5	13.5	18.0
20.0	13.5	13.5	13.5	13.5	13.5	13.5	13.5	13.5	13.5	20.0
22.0	13.5	13.5	13.5	13.5	13.5	13.5	13.5	13.5	13.5	22.0
24.0	13.5	13.5	13.5	13.5	13.5	13.5	13.5	13.5	13.5	24.0
26.0	13.5	13.5	13.5	13.5	13.5	13.5	13.5	13.5	13.5	26.0
28.0	13.5	13.5	13.5	13.5	13.5	13.5	13.5	13.5	13.5	28.0
30.0	13.5	13.5	13.5	13.5	13.5	13.5	13.5	13.5	13.5	30.0
32.0	13.5	13.5	13.5	13.5	13.5	13.5	13.5	13.5	13.5	32.0
34.0	13.5	13.5	13.5	13.5	13.5	13.5	13.5	13.5	13.5	34.0
36.0	13.5	13.5	13.5	13.5	13.5	13.5	13.5	13.5	13.5	36.0
38.0	13.5	13.5	13.5	13.5	13.5	13.5	13.5	13.3	13.2	38.0
40.0	13.5	13.5	13.2	13.0	12.7	12.6	12.3	12.0	11.9	40.0
42.0	12.6	12.3	12.0	11.8	11.6	11.4	11.1	10.9	10.8	42.0
44.0	11.5	11.3	11.0	10.8	10.5	10.4	10.1	9.8	9.7	44.0
46.0	10.9/45.1m	10.4	10.1	9.8	9.6	9.4	9.1	8.9	8.8	46.0
48.0		9.6/47.8m	9.3	9.0	8.7	8.6	8.3	8.0	7.9	48.0
50.0			8.5	8.2	8.0	7.8	7.5	7.2	7.1	50.0
52.0			8.3/50.4m	7.4	7.3	7.1	6.8	6.5	6.4	52.0
54.0				7.0/53.1m	6.6	6.4	6.1	5.8	5.7	54.0
56.0					6.0/55.7m	5.8	5.5	5.2	5.1	56.0
58.0						5.2	5.0	4.7	4.5	58.0
60.0						5.1/58.3m	4.5	4.1	3.8	60.0
62.0							4.3/61.0m	3.5	3.3	62.0
64.0								3.0/63.6m	2.7	64.0

※表中の太線で囲まれた部分は、ブーム等の強度によって定められた値です。

▶ 補助シーブ定格総荷重表 (100tフック装着)

(単位:t)

ブーム長さ 作業半径 (m)	18.3	21.3	24.4	27.4	30.5	33.5	36.6	39.6	42.7	45.7	ブーム長さ 作業半径 (m)
5.0	13.5/5.7m										5.0
6.0	13.5	13.5/6.3m	13.5/6.8m								6.0
7.0	13.5	13.5	13.5	13.5/7.3m	13.5/7.8m						7.0
8.0	13.5	13.5	13.5	13.5	13.5	13.5/8.4m	13.5/8.9m				8.0
9.0	13.5	13.5	13.5	13.5	13.5	13.5	13.5	13.5/9.4m			9.0
10.0	13.5	13.5	13.5	13.5	13.5	13.5	13.5	13.5	13.5	13.5/10.5m	10.0
12.0	13.5	13.5	13.5	13.5	13.5	13.5	13.5	13.5	13.5	13.5	12.0
14.0	13.5	13.5	13.5	13.5	13.5	13.5	13.5	13.5	13.5	13.5	14.0
16.0	13.5	13.5	13.5	13.5	13.5	13.5	13.5	13.5	13.5	13.5	16.0
18.0	13.5	13.5	13.5	13.5	13.5	13.5	13.5	13.5	13.5	13.5	18.0
20.0	13.5/18.7m	13.5	13.5	13.5	13.5	13.5	13.5	13.5	13.5	13.5	20.0
22.0		13.5/21.4m	13.5	13.5	13.5	13.5	13.5	13.5	13.5	13.5	22.0
24.0			13.5	13.5	13.5	13.5	13.5	13.5	13.5	13.5	24.0
26.0				13.5	13.5	13.5	13.5	13.5	13.5	13.5	26.0
28.0				13.5/26.7m	13.5	13.5	13.5	13.5	13.5	13.5	28.0
30.0					13.5/29.3m	13.5	13.5	13.5	13.5	13.5	30.0
32.0						13.5	13.5	13.5	13.5	13.5	32.0
34.0							13.5	13.5	13.5	13.5	34.0
36.0							13.5/34.6m	13.5	13.5	13.5	36.0
38.0								13.5/37.2m	13.5	13.5	38.0
40.0									13.5/39.9m	13.5	40.0
42.0										13.2	42.0
44.0										12.9/42.5m	44.0

※表中の太線で囲まれた部分は、ブーム等の強度によって定められた値です。

(単位:t)

ブーム長さ 作業半径 (m)	48.8	51.8	54.9	57.9	61.0	64.0	67.1	70.1	73.2	ブーム長さ 作業半径 (m)
10.0	13.5/11.0m									10.0
12.0	13.5	13.5/11.5m	13.5/12.1m	13.5/12.6m	13.5/13.1m	13.5/13.7m				12.0
14.0	13.5	13.5	13.5	13.5	13.5	13.5	13.5/14.2m	13.5/14.7m	13.5/15.3m	14.0
16.0	13.5	13.5	13.5	13.5	13.5	13.5	13.5	13.5	13.5	16.0
18.0	13.5	13.5	13.5	13.5	13.5	13.5	13.5	13.5	13.5	18.0
20.0	13.5	13.5	13.5	13.5	13.5	13.5	13.5	13.5	13.5	20.0
22.0	13.5	13.5	13.5	13.5	13.5	13.5	13.5	13.5	13.5	22.0
24.0	13.5	13.5	13.5	13.5	13.5	13.5	13.5	13.5	13.5	24.0
26.0	13.5	13.5	13.5	13.5	13.5	13.5	13.5	13.5	13.5	26.0
28.0	13.5	13.5	13.5	13.5	13.5	13.5	13.5	13.5	13.5	28.0
30.0	13.5	13.5	13.5	13.5	13.5	13.5	13.5	13.5	13.5	30.0
32.0	13.5	13.5	13.5	13.5	13.5	13.5	13.5	13.5	13.5	32.0
34.0	13.5	13.5	13.5	13.5	13.5	13.5	13.5	13.5	13.5	34.0
36.0	13.5	13.5	13.5	13.5	13.5	13.5	13.5	13.5	13.5	36.0
38.0	13.5	13.5	13.5	13.5	13.5	13.5	13.5	13.5	13.5	38.0
40.0	13.5	13.5	13.5	13.5	13.2	13.1	12.8	12.5	12.4	40.0
42.0	13.1	12.8	12.5	12.3	12.1	11.9	11.6	11.4	11.3	42.0
44.0	12.0	11.8	11.5	11.3	11.0	10.9	10.6	10.3	10.2	44.0
46.0	11.4/45.1m	10.9	10.6	10.3	10.1	9.9	9.6	9.4	9.3	46.0
48.0		10.1/47.8m	9.8	9.5	9.2	9.1	8.8	8.5	8.4	48.0
50.0			9.0	8.7	8.5	8.3	8.0	7.7	7.6	50.0
52.0			8.8/50.4m	7.9	7.8	7.6	7.3	7.0	6.9	52.0
54.0				7.5/53.1m	7.1	6.9	6.6	6.3	6.2	54.0
56.0					6.5/55.7m	6.3	6.0	5.7	5.6	56.0
58.0						5.7	5.5	5.2	5.0	58.0
60.0						5.6/58.3m	5.0	4.6	4.3	60.0
62.0							4.8/61.0m	4.0	3.8	62.0
64.0								3.5/63.6m	3.2	64.0
66.0									2.6	66.0
68.0									2.5/66.3m	68.0

※表中の太線で囲まれた部分は、ブーム等の強度によって定められた値です。

▶ 補助シーブ定格総荷重表 (65tフック装着)

(単位:t)

ブーム長さ 作業半径(m)	18.3	21.3	24.4	27.4	30.5	33.5	36.6	39.6	42.7	45.7	ブーム長さ 作業半径(m)
5.0	13.5/5.7m										5.0
6.0	13.5	13.5/6.3m	13.5/6.8m								6.0
7.0	13.5	13.5	13.5	13.5/7.3m	13.5/7.8m						7.0
8.0	13.5	13.5	13.5	13.5	13.5	13.5/8.4m	13.5/8.9m				8.0
9.0	13.5	13.5	13.5	13.5	13.5	13.5	13.5	13.5/9.4m			9.0
10.0	13.5	13.5	13.5	13.5	13.5	13.5	13.5	13.5	13.5	13.5/10.5m	10.0
12.0	13.5	13.5	13.5	13.5	13.5	13.5	13.5	13.5	13.5	13.5	12.0
14.0	13.5	13.5	13.5	13.5	13.5	13.5	13.5	13.5	13.5	13.5	14.0
16.0	13.5	13.5	13.5	13.5	13.5	13.5	13.5	13.5	13.5	13.5	16.0
18.0	13.5	13.5	13.5	13.5	13.5	13.5	13.5	13.5	13.5	13.5	18.0
20.0	13.5/18.7m	13.5	13.5	13.5	13.5	13.5	13.5	13.5	13.5	13.5	20.0
22.0		13.5/21.4m	13.5	13.5	13.5	13.5	13.5	13.5	13.5	13.5	22.0
24.0			13.5	13.5	13.5	13.5	13.5	13.5	13.5	13.5	24.0
26.0				13.5	13.5	13.5	13.5	13.5	13.5	13.5	26.0
28.0				13.5/26.7m	13.5	13.5	13.5	13.5	13.5	13.5	28.0
30.0					13.5/29.3m	13.5	13.5	13.5	13.5	13.5	30.0
32.0						13.5	13.5	13.5	13.5	13.5	32.0
34.0							13.5	13.5	13.5	13.5	34.0
36.0							13.5/34.6m	13.5	13.5	13.5	36.0
38.0								13.5/37.2m	13.5	13.5	38.0
40.0									13.5/39.9m	13.5	40.0
42.0										13.5	42.0
44.0										13.5/42.5m	44.0

※表中の太線で囲まれた部分は、ブーム等の強度によって定められた値です。

(単位:t)

ブーム長さ 作業半径(m)	48.8	51.8	54.9	57.9	61.0	64.0	67.1	70.1	73.2	ブーム長さ 作業半径(m)
10.0	13.5/11.0m									10.0
12.0	13.5	13.5/11.5m	13.5/12.1m	13.5/12.6m	13.5/13.1m	13.5/13.7m				12.0
14.0	13.5	13.5	13.5	13.5	13.5	13.5	13.5/14.2m	13.5/14.7m	13.5/15.3m	14.0
16.0	13.5	13.5	13.5	13.5	13.5	13.5	13.5	13.5	13.5	16.0
18.0	13.5	13.5	13.5	13.5	13.5	13.5	13.5	13.5	13.5	18.0
20.0	13.5	13.5	13.5	13.5	13.5	13.5	13.5	13.5	13.5	20.0
22.0	13.5	13.5	13.5	13.5	13.5	13.5	13.5	13.5	13.5	22.0
24.0	13.5	13.5	13.5	13.5	13.5	13.5	13.5	13.5	13.5	24.0
26.0	13.5	13.5	13.5	13.5	13.5	13.5	13.5	13.5	13.5	26.0
28.0	13.5	13.5	13.5	13.5	13.5	13.5	13.5	13.5	13.5	28.0
30.0	13.5	13.5	13.5	13.5	13.5	13.5	13.5	13.5	13.5	30.0
32.0	13.5	13.5	13.5	13.5	13.5	13.5	13.5	13.5	13.5	32.0
34.0	13.5	13.5	13.5	13.5	13.5	13.5	13.5	13.5	13.5	34.0
36.0	13.5	13.5	13.5	13.5	13.5	13.5	13.5	13.5	13.5	36.0
38.0	13.5	13.5	13.5	13.5	13.5	13.5	13.5	13.5	13.5	38.0
40.0	13.5	13.5	13.5	13.5	13.5	13.5	13.4	13.1	13.0	40.0
42.0	13.5	13.4	13.1	12.9	12.7	12.5	12.2	12.0	11.9	42.0
44.0	12.6	12.4	12.1	11.9	11.6	11.5	11.2	10.9	10.8	44.0
46.0	12.0/45.1m	11.5	11.2	10.9	10.7	10.5	10.2	10.0	9.9	46.0
48.0		10.7/47.8m	10.4	10.1	9.8	9.7	9.4	9.1	9.0	48.0
50.0			9.6	9.3	9.1	8.9	8.6	8.3	8.2	50.0
52.0			9.4/50.4m	8.5	8.4	8.2	7.9	7.6	7.5	52.0
54.0				8.1/53.1m	7.7	7.5	7.2	6.9	6.8	54.0
56.0					7.1/55.7m	6.9	6.6	6.3	6.2	56.0
58.0						6.3	6.1	5.8	5.6	58.0
60.0						6.2/58.3m	5.6	5.2	4.9	60.0
62.0							5.4/61.0m	4.6	4.4	62.0
64.0								4.1/63.6m	3.8	64.0
66.0									3.2	66.0
68.0									3.1/66.3m	68.0

※表中の太線で囲まれた部分は、ブーム等の強度によって定められた値です。

▶ 補助シーブ定格総荷重表 (35tフック装着)

(単位:t)

ブーム長さ 作業半径(m)	18.3	21.3	24.4	27.4	30.5	33.5	36.6	39.6	42.7	45.7	ブーム長さ 作業半径(m)
5.0	13.5/5.7m										5.0
6.0	13.5	13.5/6.3m	13.5/6.8m								6.0
7.0	13.5	13.5	13.5	13.5/7.3m	13.5/7.8m						7.0
8.0	13.5	13.5	13.5	13.5	13.5	13.5/8.4m	13.5/8.9m				8.0
9.0	13.5	13.5	13.5	13.5	13.5	13.5	13.5	13.5/9.4m			9.0
10.0	13.5	13.5	13.5	13.5	13.5	13.5	13.5	13.5	13.5	13.5/10.5m	10.0
12.0	13.5	13.5	13.5	13.5	13.5	13.5	13.5	13.5	13.5	13.5	12.0
14.0	13.5	13.5	13.5	13.5	13.5	13.5	13.5	13.5	13.5	13.5	14.0
16.0	13.5	13.5	13.5	13.5	13.5	13.5	13.5	13.5	13.5	13.5	16.0
18.0	13.5	13.5	13.5	13.5	13.5	13.5	13.5	13.5	13.5	13.5	18.0
20.0	13.5/18.7m	13.5	13.5	13.5	13.5	13.5	13.5	13.5	13.5	13.5	20.0
22.0		13.5/21.4m	13.5	13.5	13.5	13.5	13.5	13.5	13.5	13.5	22.0
24.0			13.5	13.5	13.5	13.5	13.5	13.5	13.5	13.5	24.0
26.0				13.5	13.5	13.5	13.5	13.5	13.5	13.5	26.0
28.0				13.5/26.7m	13.5	13.5	13.5	13.5	13.5	13.5	28.0
30.0					13.5/29.3m	13.5	13.5	13.5	13.5	13.5	30.0
32.0						13.5	13.5	13.5	13.5	13.5	32.0
34.0							13.5	13.5	13.5	13.5	34.0
36.0							13.5/34.6m	13.5	13.5	13.5	36.0
38.0								13.5/37.2m	13.5	13.5	38.0
40.0									13.5/39.9m	13.5	40.0
42.0										13.5	42.0
44.0										13.5/42.5m	44.0

※表中の太線で囲まれた部分は、ブーム等の強度によって定められた値です。

(単位:t)

ブーム長さ 作業半径(m)	48.8	51.8	54.9	57.9	61.0	64.0	67.1	70.1	73.2	ブーム長さ 作業半径(m)
10.0	13.5/11.0m									10.0
12.0	13.5	13.5/11.5m	13.5/12.1m	13.5/12.6m	13.5/13.1m	13.5/13.7m				12.0
14.0	13.5	13.5	13.5	13.5	13.5	13.5	13.5/14.2m	13.5/14.7m	13.5/15.3m	14.0
16.0	13.5	13.5	13.5	13.5	13.5	13.5	13.5	13.5	13.5	16.0
18.0	13.5	13.5	13.5	13.5	13.5	13.5	13.5	13.5	13.5	18.0
20.0	13.5	13.5	13.5	13.5	13.5	13.5	13.5	13.5	13.5	20.0
22.0	13.5	13.5	13.5	13.5	13.5	13.5	13.5	13.5	13.5	22.0
24.0	13.5	13.5	13.5	13.5	13.5	13.5	13.5	13.5	13.5	24.0
26.0	13.5	13.5	13.5	13.5	13.5	13.5	13.5	13.5	13.5	26.0
28.0	13.5	13.5	13.5	13.5	13.5	13.5	13.5	13.5	13.5	28.0
30.0	13.5	13.5	13.5	13.5	13.5	13.5	13.5	13.5	13.5	30.0
32.0	13.5	13.5	13.5	13.5	13.5	13.5	13.5	13.5	13.5	32.0
34.0	13.5	13.5	13.5	13.5	13.5	13.5	13.5	13.5	13.5	34.0
36.0	13.5	13.5	13.5	13.5	13.5	13.5	13.5	13.5	13.5	36.0
38.0	13.5	13.5	13.5	13.5	13.5	13.5	13.5	13.5	13.5	38.0
40.0	13.5	13.5	13.5	13.5	13.5	13.5	13.5	13.4	13.3	40.0
42.0	13.5	13.5	13.4	13.2	13.0	12.8	12.5	12.3	12.2	42.0
44.0	12.9	12.7	12.4	12.2	11.9	11.8	11.5	11.2	11.1	44.0
46.0	12.3/45.1m	11.8	11.5	11.2	11.0	10.8	10.5	10.3	10.2	46.0
48.0		11.0/47.8m	10.7	10.4	10.1	10.0	9.7	9.4	9.3	48.0
50.0			9.9	9.6	9.4	9.2	8.9	8.6	8.5	50.0
52.0			9.7/50.4m	8.8	8.7	8.5	8.2	7.9	7.8	52.0
54.0				8.4/53.1m	8.0	7.8	7.5	7.2	7.1	54.0
56.0					7.4/55.7m	7.2	6.9	6.6	6.5	56.0
58.0						6.6	6.4	6.1	5.9	58.0
60.0						6.5/58.3m	5.9	5.5	5.2	60.0
62.0							5.7/61.0m	4.9	4.7	62.0
64.0								4.4/63.6m	4.1	64.0
66.0									3.5	66.0
68.0									3.4/66.3m	68.0

※表中の太線で囲まれた部分は、ブーム等の強度によって定められた値です。

▶ 補助シーブ定格総荷重表 (主ブームにフックなし)

(単位:t)

ブーム長さ 作業半径(m)	18.3	21.3	24.4	27.4	30.5	33.5	36.6	39.6	42.7	45.7	ブーム長さ 作業半径(m)
5.0	13.5/5.7m										5.0
6.0	13.5	13.5/6.3m	13.5/6.8m								6.0
7.0	13.5	13.5	13.5	13.5/7.3m	13.5/7.8m						7.0
8.0	13.5	13.5	13.5	13.5	13.5	13.5/8.4m	13.5/8.9m				8.0
9.0	13.5	13.5	13.5	13.5	13.5	13.5	13.5	13.5/9.4m			9.0
10.0	13.5	13.5	13.5	13.5	13.5	13.5	13.5	13.5	13.5/10.0m	13.5/10.5m	10.0
12.0	13.5	13.5	13.5	13.5	13.5	13.5	13.5	13.5	13.5	13.5	12.0
14.0	13.5	13.5	13.5	13.5	13.5	13.5	13.5	13.5	13.5	13.5	14.0
16.0	13.5	13.5	13.5	13.5	13.5	13.5	13.5	13.5	13.5	13.5	16.0
18.0	13.5	13.5	13.5	13.5	13.5	13.5	13.5	13.5	13.5	13.5	18.0
20.0	13.5/18.7m	13.5	13.5	13.5	13.5	13.5	13.5	13.5	13.5	13.5	20.0
22.0		13.5/21.4m	13.5	13.5	13.5	13.5	13.5	13.5	13.5	13.5	22.0
24.0			13.5/24.0m	13.5	13.5	13.5	13.5	13.5	13.5	13.5	24.0
26.0				13.5	13.5	13.5	13.5	13.5	13.5	13.5	26.0
28.0				13.5/26.7m	13.5	13.5	13.5	13.5	13.5	13.5	28.0
30.0					13.5/29.3m	13.5	13.5	13.5	13.5	13.5	30.0
32.0						13.5/32.0m	13.5	13.5	13.5	13.5	32.0
34.0							13.5	13.5	13.5	13.5	34.0
36.0							13.5/34.6m	13.5	13.5	13.5	36.0
38.0								13.5/37.2m	13.5	13.5	38.0
40.0									13.5/39.9m	13.5	40.0
42.0										13.5	42.0
44.0										13.5/42.5m	44.0

※表中の太線で囲まれた部分は、ブーム等の強度によって定められた値です。

(単位:t)

ブーム長さ 作業半径(m)	48.8	51.8	54.9	57.9	61.0	64.0	67.1	70.1	73.2	ブーム長さ 作業半径(m)
10.0	13.5/11.0m									10.0
12.0	13.5	13.5/11.5m	13.5/12.1m	13.5/12.6m	13.5/13.1m	13.5/13.7m				12.0
14.0	13.5	13.5	13.5	13.5	13.5	13.5	13.5/14.2m	13.5/14.7m	13.5/15.3m	14.0
16.0	13.5	13.5	13.5	13.5	13.5	13.5	13.5	13.5	13.5	16.0
18.0	13.5	13.5	13.5	13.5	13.5	13.5	13.5	13.5	13.5	18.0
20.0	13.5	13.5	13.5	13.5	13.5	13.5	13.5	13.5	13.5	20.0
22.0	13.5	13.5	13.5	13.5	13.5	13.5	13.5	13.5	13.5	22.0
24.0	13.5	13.5	13.5	13.5	13.5	13.5	13.5	13.5	13.5	24.0
26.0	13.5	13.5	13.5	13.5	13.5	13.5	13.5	13.5	13.5	26.0
28.0	13.5	13.5	13.5	13.5	13.5	13.5	13.5	13.5	13.5	28.0
30.0	13.5	13.5	13.5	13.5	13.5	13.5	13.5	13.5	13.5	30.0
32.0	13.5	13.5	13.5	13.5	13.5	13.5	13.5	13.5	13.5	32.0
34.0	13.5	13.5	13.5	13.5	13.5	13.5	13.5	13.5	13.5	34.0
36.0	13.5	13.5	13.5	13.5	13.5	13.5	13.5	13.5	13.5	36.0
38.0	13.5	13.5	13.5	13.5	13.5	13.5	13.5	13.5	13.5	38.0
40.0	13.5	13.5	13.5	13.5	13.5	13.5	13.5	13.5	13.5	40.0
42.0	13.5	13.5	13.5	13.5	13.5	13.5	13.4	13.2	13.1	42.0
44.0	13.5	13.5	13.3	13.1	12.8	12.7	12.4	12.1	12.0	44.0
46.0	13.2/45.1m	12.7	12.4	12.1	11.9	11.7	11.4	11.2	11.1	46.0
48.0		11.9/47.8m	11.6	11.3	11.0	10.9	10.6	10.3	10.2	48.0
50.0			10.8	10.5	10.3	10.1	9.8	9.5	9.4	50.0
52.0			10.6/50.4m	9.7	9.6	9.4	9.1	8.8	8.7	52.0
54.0				9.3/53.1m	8.9	8.7	8.4	8.1	8.0	54.0
56.0					8.3/55.7m	8.1	7.8	7.5	7.4	56.0
58.0						7.5	7.3	7.0	6.8	58.0
60.0						7.4/58.3m	6.8	6.4	6.1	60.0
62.0							6.6/61.0m	5.8	5.6	62.0
64.0								5.3/63.6m	5.0	64.0
66.0									4.4	66.0
68.0									4.3/66.3m	68.0

※表中の太線で囲まれた部分は、ブーム等の強度によって定められた値です。



主ブーム定格総荷重表 (75.1tカウンタウエイト/カーボディウエイトなし)(オプション)

(単位:t)

ブーム長さ (m) 作業半径(m)	18.3	21.3	24.4	27.4	30.5	33.5	36.6	39.6	42.7	45.7	ブーム長さ (m) 作業半径(m)
5.0	200.0	175.0/5.5m									5.0
6.0	178.3	175.0	150.0	150.0/6.6m							6.0
7.0	154.2	153.8	150.0	150.0	125.0/7.1m	125.0/7.6m					7.0
8.0	133.1	133.0	132.9	132.8	125.0	125.0	100.0/8.2m	100.0/8.7m			8.0
9.0	109.1	108.9	108.8	108.7	108.6	108.4	100.0	100.0	98.8/9.2m	87.5/9.7m	9.0
10.0	92.2	92.1	91.9	91.8	91.6	91.5	91.5	91.2	91.1	87.5	10.0
12.0	70.2	69.9	69.8	69.6	69.4	69.2	69.2	68.9	68.7	68.6	12.0
14.0	56.4	56.1	55.9	55.7	55.5	55.3	55.2	55.0	54.8	54.6	14.0
16.0	47.0	46.7	46.4	46.2	46.0	45.8	45.7	45.4	45.2	45.1	16.0
18.0	41.9/17.4m	39.8	39.5	39.3	39.1	38.8	38.8	38.4	38.2	38.1	18.0
20.0		34.7	34.3	34.1	33.8	33.6	33.5	33.2	32.9	32.8	20.0
22.0		34.5/20.1m	30.2	30.0	29.7	29.4	29.3	29.0	28.8	28.6	22.0
24.0			29.0/22.7m	26.7	26.4	26.1	26.0	25.7	25.4	25.3	24.0
26.0				24.9/25.4m	23.7	23.4	23.3	22.9	22.7	22.5	26.0
28.0					21.4	21.1	21.0	20.6	20.4	20.2	28.0
30.0						19.2	19.1	18.7	18.4	18.2	30.0
32.0						18.7/30.6m	17.4	17.0	16.8	16.6	32.0
34.0							16.5/33.3m	15.6	15.3	15.1	34.0
36.0								14.4/35.9m	14.1	13.9	36.0
38.0									13.0	12.8	38.0
40.0									12.7/38.6m	11.8	40.0
42.0										11.3/41.2m	42.0

※表中の太線で囲まれた部分は、ブーム等の強度によって定められた値です。

(単位:t)

ブーム長さ (m) 作業半径(m)	48.8	51.8	54.9	57.9	61.0	64.0	67.1	70.1	73.2	ブーム長さ (m) 作業半径(m)
10.0	75.0/10.3m	75.0/10.8m	71.6/11.3m	62.5/11.9m						10.0
12.0	68.5	68.3	68.1	62.5	61.0/12.4m	50.0/12.9m	50.0/13.4m			12.0
14.0	54.5	54.3	54.1	54.0	53.8	50.0	50.0	47.5	37.5/14.5m	14.0
16.0	44.9	44.7	44.5	44.3	44.1	44.0	43.8	43.6	37.5	16.0
18.0	37.9	37.7	37.5	37.3	37.1	37.0	36.8	36.5	36.5	18.0
20.0	32.6	32.4	32.1	32.0	31.8	31.7	31.4	31.2	31.1	20.0
22.0	28.4	28.2	28.0	27.8	27.6	27.5	27.2	27.0	26.9	22.0
24.0	25.1	24.8	24.6	24.4	24.2	24.1	23.8	23.6	23.5	24.0
26.0	22.3	22.1	21.8	21.6	21.4	21.3	21.0	20.8	20.7	26.0
28.0	20.0	19.7	19.5	19.3	19.1	19.0	18.7	18.4	18.4	28.0
30.0	18.0	17.8	17.5	17.3	17.1	17.0	16.7	16.5	16.4	30.0
32.0	16.3	16.1	15.8	15.6	15.4	15.3	15.0	14.7	14.7	32.0
34.0	14.9	14.6	14.4	14.2	13.9	13.8	13.5	13.3	13.2	34.0
36.0	13.6	13.3	13.1	12.9	12.6	12.5	12.2	12.0	11.9	36.0
38.0	12.5	12.2	11.9	11.7	11.5	11.3	11.0	10.8	10.7	38.0
40.0	11.5	11.2	10.9	10.7	10.5	10.3	10.0	9.8	9.7	40.0
42.0	10.6	10.3	10.1	9.8	9.6	9.4	9.1	8.9	8.8	42.0
44.0	9.9/43.8m	9.5	9.3	9.0	8.8	8.6	8.3	8.0	7.9	44.0
46.0		8.8	8.5	8.3	8.0	7.9	7.6	7.3	7.1	46.0
48.0		8.7/46.5m	7.9	7.6	7.4	7.2	6.8	6.5	6.3	48.0
50.0			7.6/49.1m	7.0	6.8	6.5	6.1	5.7	5.6	50.0
52.0				6.6/51.8m	6.1	5.9	5.4	5.1	4.9	52.0
54.0					5.5	5.3	4.8	4.5	4.3	54.0
56.0					5.4/54.4m	4.7	4.3	3.9	3.7	56.0
58.0						4.5/57.0m	3.8	3.4	3.2	58.0
60.0							3.4/59.7m	2.9	2.7	60.0
62.0								2.5		62.0
64.0								2.4/62.3m		64.0

※表中の太線で囲まれた部分は、ブーム等の強度によって定められた値です。

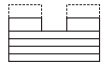

▶ 補助シーブ定格総荷重表 (75.1tカウンタウエイト/カーボディウエイトなし、200tフック装着)(オプション)

(単位:t)

ブーム長さ 作業半径(m)	18.3	21.3	24.4	27.4	30.5	33.5	36.6	39.6	42.7	45.7	ブーム長さ 作業半径(m)
5.0	13.5/5.7m										5.0
6.0	13.5	13.5/6.3m	13.5/6.8m								6.0
7.0	13.5	13.5	13.5	13.5/7.3m	13.5/7.8m						7.0
8.0	13.5	13.5	13.5	13.5	13.5	13.5/8.4m	13.5/8.9m				8.0
9.0	13.5	13.5	13.5	13.5	13.5	13.5	13.5	13.5/9.4m			9.0
10.0	13.5	13.5	13.5	13.5	13.5	13.5	13.5	13.5	13.5	13.5/10.5m	10.0
12.0	13.5	13.5	13.5	13.5	13.5	13.5	13.5	13.5	13.5	13.5	12.0
14.0	13.5	13.5	13.5	13.5	13.5	13.5	13.5	13.5	13.5	13.5	14.0
16.0	13.5	13.5	13.5	13.5	13.5	13.5	13.5	13.5	13.5	13.5	16.0
18.0	13.5	13.5	13.5	13.5	13.5	13.5	13.5	13.5	13.5	13.5	18.0
20.0	13.5/18.7m	13.5	13.5	13.5	13.5	13.5	13.5	13.5	13.5	13.5	20.0
22.0		13.5/21.4m	13.5	13.5	13.5	13.5	13.5	13.5	13.5	13.5	22.0
24.0			13.5	13.5	13.5	13.5	13.5	13.5	13.5	13.5	24.0
26.0				13.5	13.5	13.5	13.5	13.5	13.5	13.5	26.0
28.0				13.5/26.7m	13.5	13.5	13.5	13.5	13.5	13.5	28.0
30.0					13.5/29.3m	13.5	13.5	13.5	13.5	13.5	30.0
32.0						13.5	13.5	13.5	13.5	13.5	32.0
34.0							12.6	12.5	12.2	12.0	34.0
36.0							12.1/34.6m	11.1	11.0	10.8	36.0
38.0								10.3/37.2m	9.9	9.7	38.0
40.0									8.9/39.9m	8.7	40.0
42.0										7.7	42.0
44.0										7.5/42.5m	44.0

※表中の太線で囲まれた部分は、ブーム等の強度によって定められた値です。

(単位:t)

ブーム長さ 作業半径(m)	48.8	51.8	54.9	57.9	61.0	64.0	67.1	70.1	73.2	ブーム長さ 作業半径(m)
10.0	13.5/11.0m									10.0
12.0	13.5	13.5/11.5m	13.5/12.1m	13.5/12.6m	13.5/13.1m	13.5/13.7m				12.0
14.0	13.5	13.5	13.5	13.5	13.5	13.5	13.5/14.2m	13.5/14.7m	13.5/15.3m	14.0
16.0	13.5	13.5	13.5	13.5	13.5	13.5	13.5	13.5	13.5	16.0
18.0	13.5	13.5	13.5	13.5	13.5	13.5	13.5	13.5	13.5	18.0
20.0	13.5	13.5	13.5	13.5	13.5	13.5	13.5	13.5	13.5	20.0
22.0	13.5	13.5	13.5	13.5	13.5	13.5	13.5	13.5	13.5	22.0
24.0	13.5	13.5	13.5	13.5	13.5	13.5	13.5	13.5	13.5	24.0
26.0	13.5	13.5	13.5	13.5	13.5	13.5	13.5	13.5	13.5	26.0
28.0	13.5	13.5	13.5	13.5	13.5	13.5	13.5	13.5	13.5	28.0
30.0	13.5	13.5	13.5	13.5	13.5	13.5	13.5	13.4	13.3	30.0
32.0	13.2	13.0	12.7	12.5	12.3	12.2	11.9	11.6	11.6	32.0
34.0	11.8	11.5	11.3	11.1	10.8	10.7	10.4	10.2	10.1	34.0
36.0	10.5	10.2	10.0	9.8	9.5	9.4	9.1	8.9	8.8	36.0
38.0	9.4	9.1	8.8	8.6	8.4	8.2	7.9	7.7	7.6	38.0
40.0	8.4	8.1	7.8	7.6	7.4	7.2	6.9	6.7	6.6	40.0
42.0	7.5	7.2	7.0	6.7	6.5	6.3	6.0	5.8	5.7	42.0
44.0	6.6	6.4	6.2	5.9	5.7	5.5	5.2	4.9	4.8	44.0
46.0	6.1/45.1m	5.7	5.4	5.2	4.9	4.8	4.5	4.2	4.0	46.0
48.0		6.1/47.8m	4.8	4.5	4.3	4.1	3.7	3.4	3.2	48.0
50.0			4.2	3.9	3.7	3.4	3.0	2.6	2.5	50.0
52.0			4.1/50.4m	3.3	3.0	2.8	2.3			52.0
54.0				3.0/53.1m	2.4	2.2				54.0

※表中の太線で囲まれた部分は、ブーム等の強度によって定められた値です。



▶ 補助シーブ定格総荷重表 (75.1tカウンタウエイト/カーボディウエイトなし、150tフック装着)(オプション)

(単位:t)

ブーム長さ 作業半径(m)	18.3	21.3	24.4	27.4	30.5	33.5	36.6	39.6	42.7	45.7	ブーム長さ 作業半径(m)
5.0	13.5/5.7m										5.0
6.0	13.5	13.5/6.3m	13.5/6.8m								6.0
7.0	13.5	13.5	13.5	13.5/7.3m	13.5/7.8m						7.0
8.0	13.5	13.5	13.5	13.5	13.5	13.5/8.4m	13.5/8.9m				8.0
9.0	13.5	13.5	13.5	13.5	13.5	13.5	13.5	13.5/9.4m			9.0
10.0	13.5	13.5	13.5	13.5	13.5	13.5	13.5	13.5	13.5	13.5/10.5m	10.0
12.0	13.5	13.5	13.5	13.5	13.5	13.5	13.5	13.5	13.5	13.5	12.0
14.0	13.5	13.5	13.5	13.5	13.5	13.5	13.5	13.5	13.5	13.5	14.0
16.0	13.5	13.5	13.5	13.5	13.5	13.5	13.5	13.5	13.5	13.5	16.0
18.0	13.5	13.5	13.5	13.5	13.5	13.5	13.5	13.5	13.5	13.5	18.0
20.0	13.5/18.7m	13.5	13.5	13.5	13.5	13.5	13.5	13.5	13.5	13.5	20.0
22.0		13.5/21.4m	13.5	13.5	13.5	13.5	13.5	13.5	13.5	13.5	22.0
24.0			13.5	13.5	13.5	13.5	13.5	13.5	13.5	13.5	24.0
26.0				13.5	13.5	13.5	13.5	13.5	13.5	13.5	26.0
28.0				13.5/26.7m	13.5	13.5	13.5	13.5	13.5	13.5	28.0
30.0					13.5/29.3m	13.5	13.5	13.5	13.5	13.5	30.0
32.0						13.5	13.5	13.5	13.5	13.5	32.0
34.0							13.1	13.0	12.7	12.5	34.0
36.0							12.6/34.6m	11.6	11.5	11.3	36.0
38.0								10.8/37.2m	10.4	10.2	38.0
40.0									9.4/39.9m	9.2	40.0
42.0										8.2	42.0
44.0										8.0/42.5m	44.0

※表中の太線で囲まれた部分は、ブーム等の強度によって定められた値です。

(単位:t)

ブーム長さ 作業半径(m)	48.8	51.8	54.9	57.9	61.0	64.0	67.1	70.1	73.2	ブーム長さ 作業半径(m)
10.0	13.5/11.0m									10.0
12.0	13.5	13.5/11.5m	13.5/12.1m	13.5/12.8m	13.5/13.1m	13.5/13.7m				12.0
14.0	13.5	13.5	13.5	13.5	13.5	13.5	13.5/14.2m	13.5/14.7m	13.5/16.3m	14.0
16.0	13.5	13.5	13.5	13.5	13.5	13.5	13.5	13.5	13.5	16.0
18.0	13.5	13.5	13.5	13.5	13.5	13.5	13.5	13.5	13.5	18.0
20.0	13.5	13.5	13.5	13.5	13.5	13.5	13.5	13.5	13.5	20.0
22.0	13.5	13.5	13.5	13.5	13.5	13.5	13.5	13.5	13.5	22.0
24.0	13.5	13.5	13.5	13.5	13.5	13.5	13.5	13.5	13.5	24.0
26.0	13.5	13.5	13.5	13.5	13.5	13.5	13.5	13.5	13.5	26.0
28.0	13.5	13.5	13.5	13.5	13.5	13.5	13.5	13.5	13.5	28.0
30.0	13.5	13.5	13.5	13.5	13.5	13.5	13.5	13.5	13.5	30.0
32.0	13.5	13.5	13.2	13.0	12.8	12.7	12.4	12.1	12.1	32.0
34.0	12.3	12.0	11.8	11.6	11.3	11.2	10.9	10.7	10.6	34.0
36.0	11.0	10.7	10.5	10.3	10.0	9.9	9.6	9.4	9.3	36.0
38.0	9.9	9.6	9.3	9.1	8.9	8.7	8.4	8.2	8.1	38.0
40.0	8.9	8.6	8.3	8.1	7.9	7.7	7.4	7.2	7.1	40.0
42.0	8.0	7.7	7.5	7.2	7.0	6.8	6.5	6.3	6.2	42.0
44.0	7.1	6.9	6.7	6.4	6.2	6.0	5.7	5.4	5.3	44.0
46.0	6.6/45.1m	6.2	5.9	5.7	5.4	5.3	5.0	4.7	4.5	46.0
48.0		5.6/47.8m	5.3	5.0	4.8	4.6	4.2	3.9	3.7	48.0
50.0			4.7	4.4	4.2	3.9	3.5	3.1	3.0	50.0
52.0			4.6/50.4m	3.8	3.5	3.3	2.8	2.5		52.0
54.0				3.5/53.1m	2.9	2.7				54.0
56.0					2.4/55.7m					56.0

※表中の太線で囲まれた部分は、ブーム等の強度によって定められた値です。



▶ 補助シーブ定格総荷重表 (75.1tカウンタウエイト/カーボディウエイトなし、100tフック装着)(オプション)

(単位:t)

ブーム長さ (m) 作業半径(m)	18.3	21.3	24.4	27.4	30.5	33.5	36.6	39.6	42.7	45.7	ブーム長さ (m) 作業半径(m)
5.0	13.5/5.7m										5.0
6.0	13.5	13.5/6.3m	13.5/6.8m								6.0
7.0	13.5	13.5	13.5	13.5/7.3m	13.5/7.8m						7.0
8.0	13.5	13.5	13.5	13.5	13.5	13.5/8.4m	13.5/8.9m				8.0
9.0	13.5	13.5	13.5	13.5	13.5	13.5	13.5	13.5/9.4m			9.0
10.0	13.5	13.5	13.5	13.5	13.5	13.5	13.5	13.5	13.5	13.5/10.5m	10.0
12.0	13.5	13.5	13.5	13.5	13.5	13.5	13.5	13.5	13.5	13.5	12.0
14.0	13.5	13.5	13.5	13.5	13.5	13.5	13.5	13.5	13.5	13.5	14.0
16.0	13.5	13.5	13.5	13.5	13.5	13.5	13.5	13.5	13.5	13.5	16.0
18.0	13.5	13.5	13.5	13.5	13.5	13.5	13.5	13.5	13.5	13.5	18.0
20.0	13.5/18.7m	13.5	13.5	13.5	13.5	13.5	13.5	13.5	13.5	13.5	20.0
22.0		13.5/21.4m	13.5	13.5	13.5	13.5	13.5	13.5	13.5	13.5	22.0
24.0			13.5	13.5	13.5	13.5	13.5	13.5	13.5	13.5	24.0
26.0				13.5	13.5	13.5	13.5	13.5	13.5	13.5	26.0
28.0				13.5/26.7m	13.5	13.5	13.5	13.5	13.5	13.5	28.0
30.0					13.5/29.3m	13.5	13.5	13.5	13.5	13.5	30.0
32.0						13.5	13.5	13.5	13.5	13.5	32.0
34.0							13.5	13.5	13.2	13.0	34.0
36.0							13.1/34.6m	12.1	12.0	11.8	36.0
38.0								11.3/37.2m	10.9	10.7	38.0
40.0									9.9/39.9m	9.7	40.0
42.0										8.7	42.0
44.0										8.5/42.5m	44.0

※表中の太線で囲まれた部分は、ブーム等の強度によって定められた値です。

(単位:t)

ブーム長さ (m) 作業半径(m)	48.8	51.8	54.9	57.9	61.0	64.0	67.1	70.1	73.2	ブーム長さ (m) 作業半径(m)
10.0	13.5/11.0m									10.0
12.0	13.5	13.5/11.5m	13.5/12.1m	13.5/12.6m	13.5/13.1m	13.5/13.7m				12.0
14.0	13.5	13.5	13.5	13.5	13.5	13.5	13.5/14.2m	13.5/14.7m	13.5/15.3m	14.0
16.0	13.5	13.5	13.5	13.5	13.5	13.5	13.5	13.5	13.5	16.0
18.0	13.5	13.5	13.5	13.5	13.5	13.5	13.5	13.5	13.5	18.0
20.0	13.5	13.5	13.5	13.5	13.5	13.5	13.5	13.5	13.5	20.0
22.0	13.5	13.5	13.5	13.5	13.5	13.5	13.5	13.5	13.5	22.0
24.0	13.5	13.5	13.5	13.5	13.5	13.5	13.5	13.5	13.5	24.0
26.0	13.5	13.5	13.5	13.5	13.5	13.5	13.5	13.5	13.5	26.0
28.0	13.5	13.5	13.5	13.5	13.5	13.5	13.5	13.5	13.5	28.0
30.0	13.5	13.5	13.5	13.5	13.5	13.5	13.5	13.5	13.5	30.0
32.0	13.5	13.5	13.5	13.5	13.3	13.2	12.9	12.6	12.6	32.0
34.0	12.8	12.5	12.3	12.1	11.8	11.7	11.4	11.2	11.1	34.0
36.0	11.5	11.2	11.0	10.8	10.5	10.4	10.1	9.9	9.8	36.0
38.0	10.4	10.1	9.8	9.6	9.4	9.2	8.9	8.7	8.6	38.0
40.0	9.4	9.1	8.8	8.6	8.4	8.2	7.9	7.7	7.6	40.0
42.0	8.5	8.2	8.0	7.7	7.5	7.3	7.0	6.8	6.7	42.0
44.0	7.6	7.4	7.2	6.9	6.7	6.5	6.2	5.9	5.8	44.0
46.0	7.1/45.1m	6.7	6.4	6.2	5.9	5.8	5.5	5.2	5.0	46.0
48.0		6.1/47.8m	5.8	5.5	5.3	5.1	4.7	4.4	4.2	48.0
50.0			5.2	4.9	4.7	4.4	4.0	3.6	3.5	50.0
52.0			5.1/50.4m	4.3	4.0	3.8	3.3	3.0	2.8	52.0
54.0				4.0/53.1m	3.4	3.2	2.7	2.4		54.0
56.0					2.9/55.7m	2.6				56.0

※表中の太線で囲まれた部分は、ブーム等の強度によって定められた値です。



▶ 補助シーブ定格総荷重表 (75.1tカウンタウエイト/カーボディウエイトなし、65tフック装着)(オプション)

(単位:t)

ブーム長さ 作業半径(m)	18.3	21.3	24.4	27.4	30.5	33.5	36.6	39.6	42.7	45.7	ブーム長さ 作業半径(m)
5.0	13.5/5.7m										5.0
6.0	13.5	13.5/6.3m	13.5/6.8m								6.0
7.0	13.5	13.5	13.5	13.5/7.3m	13.5/7.8m						7.0
8.0	13.5	13.5	13.5	13.5	13.5	13.5/8.4m	13.5/8.9m				8.0
9.0	13.5	13.5	13.5	13.5	13.5	13.5	13.5	13.5/9.4m			9.0
10.0	13.5	13.5	13.5	13.5	13.5	13.5	13.5	13.5	13.5	13.5/10.5m	10.0
12.0	13.5	13.5	13.5	13.5	13.5	13.5	13.5	13.5	13.5	13.5	12.0
14.0	13.5	13.5	13.5	13.5	13.5	13.5	13.5	13.5	13.5	13.5	14.0
16.0	13.5	13.5	13.5	13.5	13.5	13.5	13.5	13.5	13.5	13.5	16.0
18.0	13.5	13.5	13.5	13.5	13.5	13.5	13.5	13.5	13.5	13.5	18.0
20.0	13.5/18.7m	13.5	13.5	13.5	13.5	13.5	13.5	13.5	13.5	13.5	20.0
22.0		13.5/21.4m	13.5	13.5	13.5	13.5	13.5	13.5	13.5	13.5	22.0
24.0			13.5	13.5	13.5	13.5	13.5	13.5	13.5	13.5	24.0
26.0				13.5	13.5	13.5	13.5	13.5	13.5	13.5	26.0
28.0				13.5/26.7m	13.5	13.5	13.5	13.5	13.5	13.5	28.0
30.0					13.5/29.3m	13.5	13.5	13.5	13.5	13.5	30.0
32.0						13.5	13.5	13.5	13.5	13.5	32.0
34.0							13.5	13.5	13.5	13.5	34.0
36.0							13.5/34.6m	12.7	12.6	12.4	36.0
38.0								11.9/37.2m	11.5	11.3	38.0
40.0									10.5/39.9m	10.3	40.0
42.0										9.3	42.0
44.0										9.1/42.5m	44.0

※表中の太線で囲まれた部分は、ブーム等の強度によって定められた値です。

(単位:t)

ブーム長さ 作業半径(m)	48.8	51.8	54.9	57.9	61.0	64.0	67.1	70.1	73.2	ブーム長さ 作業半径(m)
10.0	13.5/11.0m									10.0
12.0	13.5	13.5/11.5m	13.5/12.1m	13.5/12.6m	13.5/13.1m	13.5/13.7m				12.0
14.0	13.5	13.5	13.5	13.5	13.5	13.5	13.5/14.2m	13.5/14.7m	13.5/15.3m	14.0
16.0	13.5	13.5	13.5	13.5	13.5	13.5	13.5	13.5	13.5	16.0
18.0	13.5	13.5	13.5	13.5	13.5	13.5	13.5	13.5	13.5	18.0
20.0	13.5	13.5	13.5	13.5	13.5	13.5	13.5	13.5	13.5	20.0
22.0	13.5	13.5	13.5	13.5	13.5	13.5	13.5	13.5	13.5	22.0
24.0	13.5	13.5	13.5	13.5	13.5	13.5	13.5	13.5	13.5	24.0
26.0	13.5	13.5	13.5	13.5	13.5	13.5	13.5	13.5	13.5	26.0
28.0	13.5	13.5	13.5	13.5	13.5	13.5	13.5	13.5	13.5	28.0
30.0	13.5	13.5	13.5	13.5	13.5	13.5	13.5	13.5	13.5	30.0
32.0	13.5	13.5	13.5	13.5	13.5	13.5	13.5	13.2	13.2	32.0
34.0	13.4	13.1	12.9	12.7	12.4	12.3	12.0	11.8	11.7	34.0
36.0	12.1	11.8	11.6	11.4	11.1	11.0	10.7	10.5	10.4	36.0
38.0	11.0	10.7	10.4	10.2	10.0	9.8	9.5	9.3	9.2	38.0
40.0	10.0	9.7	9.4	9.2	9.0	8.8	8.5	8.3	8.2	40.0
42.0	9.1	8.8	8.6	8.3	8.1	7.9	7.6	7.4	7.3	42.0
44.0	8.2	8.0	7.8	7.5	7.3	7.1	6.8	6.5	6.4	44.0
46.0	7.7/45.1m	7.3	7.0	6.8	6.5	6.4	6.1	5.8	5.6	46.0
48.0		6.7/47.8m	6.4	6.1	5.9	5.7	5.3	5.0	4.8	48.0
50.0			5.8	5.5	5.3	5.0	4.6	4.2	4.1	50.0
52.0			5.7/50.4m	4.9	4.6	4.4	3.9	3.6	3.4	52.0
54.0				4.6/53.1m	4.0	3.8	3.3	3.0	2.8	54.0
56.0					3.5/55.7m	3.2	2.8	2.4		56.0
58.0						2.6				58.0
60.0						2.5/58.3m				60.0

※表中の太線で囲まれた部分は、ブーム等の強度によって定められた値です。



▶ 補助シーブ定格総荷重表 (75.1tカウンタウエイト/カーボディウエイトなし、35tフック装着)(オプション)

(単位:t)

ブーム長さ (m) 作業半径(m)	18.3	21.3	24.4	27.4	30.5	33.5	36.6	39.6	42.7	45.7	ブーム長さ (m) 作業半径(m)
5.0	13.5/5.7m										5.0
6.0	13.5	13.5/6.3m	13.5/6.8m								6.0
7.0	13.5	13.5	13.5	13.5/7.3m	13.5/7.8m						7.0
8.0	13.5	13.5	13.5	13.5	13.5	13.5/8.4m	13.5/8.9m				8.0
9.0	13.5	13.5	13.5	13.5	13.5	13.5	13.5	13.5/9.4m			9.0
10.0	13.5	13.5	13.5	13.5	13.5	13.5	13.5	13.5	13.5	13.5/10.5m	10.0
12.0	13.5	13.5	13.5	13.5	13.5	13.5	13.5	13.5	13.5	13.5	12.0
14.0	13.5	13.5	13.5	13.5	13.5	13.5	13.5	13.5	13.5	13.5	14.0
16.0	13.5	13.5	13.5	13.5	13.5	13.5	13.5	13.5	13.5	13.5	16.0
18.0	13.5	13.5	13.5	13.5	13.5	13.5	13.5	13.5	13.5	13.5	18.0
20.0	13.5/18.7m	13.5	13.5	13.5	13.5	13.5	13.5	13.5	13.5	13.5	20.0
22.0		13.5/21.4m	13.5	13.5	13.5	13.5	13.5	13.5	13.5	13.5	22.0
24.0			13.5	13.5	13.5	13.5	13.5	13.5	13.5	13.5	24.0
26.0				13.5	13.5	13.5	13.5	13.5	13.5	13.5	26.0
28.0				13.5/26.7m	13.5	13.5	13.5	13.5	13.5	13.5	28.0
30.0					13.5/29.3m	13.5	13.5	13.5	13.5	13.5	30.0
32.0						13.5	13.5	13.5	13.5	13.5	32.0
34.0							13.5	13.5	13.5	13.5	34.0
36.0							13.5/34.6m	13.0	12.9	12.7	36.0
38.0								12.2/37.2m	11.8	11.6	38.0
40.0									10.8/39.9m	10.6	40.0
42.0										9.6	42.0
44.0										9.4/42.5m	44.0

※表中の太線で囲まれた部分は、ブーム等の強度によって定められた値です。

(単位:t)

ブーム長さ (m) 作業半径(m)	48.8	51.8	54.9	57.9	61.0	64.0	67.1	70.1	73.2	ブーム長さ (m) 作業半径(m)
10.0	13.5/11.0m									10.0
12.0	13.5	13.5/11.5m	13.5/12.1m	13.5/12.6m	13.5/13.1m	13.5/13.7m				12.0
14.0	13.5	13.5	13.5	13.5	13.5	13.5	13.5/14.2m	13.5/14.7m	13.5/15.3m	14.0
16.0	13.5	13.5	13.5	13.5	13.5	13.5	13.5	13.5	13.5	16.0
18.0	13.5	13.5	13.5	13.5	13.5	13.5	13.5	13.5	13.5	18.0
20.0	13.5	13.5	13.5	13.5	13.5	13.5	13.5	13.5	13.5	20.0
22.0	13.5	13.5	13.5	13.5	13.5	13.5	13.5	13.5	13.5	22.0
24.0	13.5	13.5	13.5	13.5	13.5	13.5	13.5	13.5	13.5	24.0
26.0	13.5	13.5	13.5	13.5	13.5	13.5	13.5	13.5	13.5	26.0
28.0	13.5	13.5	13.5	13.5	13.5	13.5	13.5	13.5	13.5	28.0
30.0	13.5	13.5	13.5	13.5	13.5	13.5	13.5	13.5	13.5	30.0
32.0	13.5	13.5	13.5	13.5	13.5	13.5	13.5	13.5	13.5	32.0
34.0	13.5	13.4	13.2	13.0	12.7	12.6	12.3	12.1	12.0	34.0
36.0	12.4	12.1	11.9	11.7	11.4	11.3	11.0	10.8	10.7	36.0
38.0	11.3	11.0	10.7	10.5	10.3	10.1	9.8	9.6	9.5	38.0
40.0	10.3	10.0	9.7	9.5	9.3	9.1	8.8	8.6	8.5	40.0
42.0	9.4	9.1	8.9	8.6	8.4	8.2	7.9	7.7	7.6	42.0
44.0	8.5	8.3	8.1	7.8	7.6	7.4	7.1	6.8	6.7	44.0
46.0	8.0/45.1m	7.6	7.3	7.1	6.8	6.7	6.4	6.1	5.9	46.0
48.0		7.0/47.8m	6.7	6.4	6.2	6.0	5.6	5.3	5.1	48.0
50.0			6.1	5.8	5.6	5.3	4.9	4.5	4.4	50.0
52.0			6.0/50.4m	5.2	4.9	4.7	4.2	3.9	3.7	52.0
54.0				4.9/53.1m	4.3	4.1	3.6	3.3	3.1	54.0
56.0					3.8/55.7m	3.5	3.1	2.7	2.5	56.0
58.0						2.9	2.6			58.0
60.0							2.8/58.3m			60.0

※表中の太線で囲まれた部分は、ブーム等の強度によって定められた値です。



▶ 補助シーブ定格総荷重表 (75.1tカウンタウエイト/カーボディウエイトなし、主フックなし)(オプション)

(単位:t)

ブーム長さ 作業半径(m)	18.3	21.3	24.4	27.4	30.5	33.5	36.6	39.6	42.7	45.7	ブーム長さ 作業半径(m)
5.0	13.5/5.7m										5.0
6.0	13.5	13.5/6.3m	13.5/6.8m								6.0
7.0	13.5	13.5	13.5	13.5/7.3m	13.5/7.8m						7.0
8.0	13.5	13.5	13.5	13.5	13.5	13.5/8.4m	13.5/8.9m				8.0
9.0	13.5	13.5	13.5	13.5	13.5	13.5	13.5	13.5/9.4m			9.0
10.0	13.5	13.5	13.5	13.5	13.5	13.5	13.5	13.5	13.5	13.5/10.5m	10.0
12.0	13.5	13.5	13.5	13.5	13.5	13.5	13.5	13.5	13.5	13.5	12.0
14.0	13.5	13.5	13.5	13.5	13.5	13.5	13.5	13.5	13.5	13.5	14.0
16.0	13.5	13.5	13.5	13.5	13.5	13.5	13.5	13.5	13.5	13.5	16.0
18.0	13.5	13.5	13.5	13.5	13.5	13.5	13.5	13.5	13.5	13.5	18.0
20.0	13.5/18.7m	13.5	13.5	13.5	13.5	13.5	13.5	13.5	13.5	13.5	20.0
22.0		13.5/21.4m	13.5	13.5	13.5	13.5	13.5	13.5	13.5	13.5	22.0
24.0			13.5	13.5	13.5	13.5	13.5	13.5	13.5	13.5	24.0
26.0				13.5	13.5	13.5	13.5	13.5	13.5	13.5	26.0
28.0				13.5/26.7m	13.5	13.5	13.5	13.5	13.5	13.5	28.0
30.0					13.5/29.3m	13.5	13.5	13.5	13.5	13.5	30.0
32.0						13.5	13.5	13.5	13.5	13.5	32.0
34.0							13.5	13.5	13.5	13.5	34.0
36.0								13.5/34.6m	13.5	13.5	36.0
38.0									13.1/37.2m	12.7	38.0
40.0										11.7/39.9m	40.0
42.0										10.5	42.0
44.0										10.3/42.5m	44.0

※表中の太線で囲まれた部分は、ブーム等の強度によって定められた値です。

(単位:t)

ブーム長さ 作業半径(m)	48.8	51.8	54.9	57.9	61.0	64.0	67.1	70.1	73.2	ブーム長さ 作業半径(m)
10.0	13.5/11.0m									10.0
12.0	13.5	13.5/11.5m	13.5/12.1m	13.5/12.6m	13.5/13.1m	13.5/13.7m				12.0
14.0	13.5	13.5	13.5	13.5	13.5	13.5	13.5/14.2m	13.5/14.7m	13.5/15.3m	14.0
16.0	13.5	13.5	13.5	13.5	13.5	13.5	13.5	13.5	13.5	16.0
18.0	13.5	13.5	13.5	13.5	13.5	13.5	13.5	13.5	13.5	18.0
20.0	13.5	13.5	13.5	13.5	13.5	13.5	13.5	13.5	13.5	20.0
22.0	13.5	13.5	13.5	13.5	13.5	13.5	13.5	13.5	13.5	22.0
24.0	13.5	13.5	13.5	13.5	13.5	13.5	13.5	13.5	13.5	24.0
26.0	13.5	13.5	13.5	13.5	13.5	13.5	13.5	13.5	13.5	26.0
28.0	13.5	13.5	13.5	13.5	13.5	13.5	13.5	13.5	13.5	28.0
30.0	13.5	13.5	13.5	13.5	13.5	13.5	13.5	13.5	13.5	30.0
32.0	13.5	13.5	13.5	13.5	13.5	13.5	13.5	13.5	13.5	32.0
34.0	13.5	13.5	13.5	13.5	13.5	13.5	13.2	13.0	12.9	34.0
36.0	13.3	13.0	12.8	12.6	12.3	12.2	11.9	11.7	11.6	36.0
38.0	12.2	11.9	11.6	11.4	11.2	11.0	10.7	10.5	10.4	38.0
40.0	11.2	10.9	10.6	10.4	10.2	10.0	9.7	9.5	9.4	40.0
42.0	10.3	10.0	9.8	9.5	9.3	9.1	8.8	8.6	8.5	42.0
44.0	9.4	9.2	9.0	8.7	8.5	8.3	8.0	7.7	7.6	44.0
46.0	8.9/45.1m	8.5	8.2	8.0	7.7	7.6	7.3	7.0	6.8	46.0
48.0		7.9/47.8m	7.6	7.3	7.1	6.9	6.5	6.2	6.0	48.0
50.0			7.0	6.7	6.5	6.2	5.8	5.4	5.3	50.0
52.0			6.9/50.4m	6.1	5.8	5.6	5.1	4.8	4.6	52.0
54.0				5.8/53.1m	5.2	5.0	4.5	4.2	4.0	54.0
56.0					4.7/55.7m	4.4	4.0	3.6	3.4	56.0
58.0						3.8	3.5	3.1	2.9	58.0
60.0							3.7/58.3m	3.0	2.6	60.0
62.0								2.8/61.0m		62.0

※表中の太線で囲まれた部分は、ブーム等の強度によって定められた値です。

▶ ロング主ブーム定格総荷重表

(単位:t)

ブーム長さ 作業半径(m)	73.2	76.2	79.2	82.3	85.3	88.4	91.4	ブーム長さ 作業半径(m)
14.0	37.5/14.4m	34.5/14.9m	32.6/15.4m					14.0
16.0	36.0	33.5	32.1	31.2/16.0m	25.0/16.5m	25.0/17.0m	21.5/17.6m	16.0
18.0	34.4	31.9	30.6	29.6	25.0	25.0	21.2	18.0
20.0	32.9	30.4	29.1	28.2	25.0	24.1	20.0	20.0
22.0	31.6	29.1	27.9	26.9	25.0	23.0	18.9	22.0
24.0	30.4	27.9	26.8	25.7	24.2	22.0	17.8	24.0
26.0	28.8	26.5	25.6	24.6	23.2	21.1	16.9	26.0
28.0	26.2	25.2	24.5	23.6	22.3	20.1	16.0	28.0
30.0	23.8	23.6	23.3	22.6	21.1	19.1	15.3	30.0
32.0	21.8	21.7	21.6	21.5	19.9	18.1	14.5	32.0
34.0	19.9	19.9	19.7	19.7	18.7	17.1	13.8	34.0
36.0	18.3	18.3	18.2	18.1	17.7	16.1	13.1	36.0
38.0	16.9	16.8	16.7	16.7	16.5	15.1	12.5	38.0
40.0	15.6	15.6	15.4	15.4	15.4	14.2	11.8	40.0
42.0	14.5	14.5	14.3	14.3	14.3	13.4	11.2	42.0
44.0	13.4	13.4	13.2	13.2	13.2	12.5	10.7	44.0
46.0	12.5	12.5	12.3	12.3	12.2	11.8	10.2	46.0
48.0	11.6	11.5	11.4	11.4	11.3	11.1	9.8	48.0
50.0	10.7	10.7	10.6	10.5	10.5	10.3	9.4	50.0
52.0	10.0	10.0	9.9	9.8	9.8	9.6	8.9	52.0
54.0	9.3	9.3	9.1	9.1	9.0	9.0	8.5	54.0
56.0	8.6	8.6	8.5	8.4	8.4	8.4	7.8	56.0
58.0	8.0	8.0	7.8	7.8	7.7	7.7	7.2	58.0
60.0	7.4	7.3	7.2	7.2	7.1	7.1	6.7	60.0
62.0	6.8	6.7	6.7	6.6	6.6	6.6	6.1	62.0
64.0	6.3	6.1	6.1	6.1	6.0	6.0	5.6	64.0
66.0	6.1/64.9m	5.6	5.6	5.6	5.6	5.6	5.1	66.0
68.0		5.4/67.5m	5.3	5.2	5.2	5.2	4.6	68.0
70.0			4.8	4.7	4.7	4.7	4.1	70.0
72.0			4.8/70.2m	4.3	4.3	4.3	3.6	72.0
74.0				4.2/72.8m	3.9	3.9	3.1	74.0
76.0					3.7/74.5m	3.5	2.6/76.0m	76.0
78.0						3.2		78.0
80.0						3.2/78.1m		80.0

※表中の太線で囲まれた部分は、ブーム等の強度によって定められた値です。

▶ ロング補助シーブ定格総荷重表 (65tフック装着)

(単位:t)

ブーム長さ 作業半径(m)	73.2	76.2	79.2	82.3	85.3	88.4	ブーム長さ 作業半径(m)
14.0	13.5/15.1m	13.5/15.7m					14.0
16.0	13.5	13.5	13.5/16.2m	13.5/16.7m	13.5/17.3m	13.5/17.8m	16.0
18.0	13.5	13.5	13.5	13.5	13.5	13.5	18.0
20.0	13.5	13.5	13.5	13.5	13.5	13.5	20.0
22.0	13.5	13.5	13.5	13.5	13.5	13.5	22.0
24.0	13.5	13.5	13.5	13.5	13.5	13.5	24.0
26.0	13.5	13.5	13.5	13.5	13.5	13.5	26.0
28.0	13.5	13.5	13.5	13.5	13.5	13.5	28.0
30.0	13.5	13.5	13.5	13.5	13.5	13.5	30.0
32.0	13.5	13.5	13.5	13.5	13.5	13.5	32.0
34.0	13.5	13.5	13.5	13.5	13.5	13.5	34.0
36.0	13.5	13.5	13.5	13.5	13.5	13.5	36.0
38.0	13.5	13.5	13.5	13.5	13.5	13.5	38.0
40.0	13.5	13.5	13.5	13.5	13.5	12.7	40.0
42.0	13.0	13.0	12.8	12.8	12.8	11.9	42.0
44.0	11.9	11.9	11.7	11.7	11.7	11.0	44.0
46.0	11.0	11.0	10.8	10.8	10.7	10.3	46.0
48.0	10.1	10.0	9.9	9.9	9.8	9.6	48.0
50.0	9.2	9.2	9.1	9.0	9.0	8.8	50.0
52.0	8.5	8.5	8.4	8.3	8.3	8.1	52.0
54.0	7.8	7.8	7.6	7.6	7.5	7.5	54.0
56.0	7.1	7.1	7.0	6.9	6.9	6.9	56.0
58.0	6.5	6.5	6.3	6.3	6.2	6.2	58.0
60.0	5.9	5.8	5.7	5.7	5.6	5.6	60.0
62.0	5.3	5.2	5.2	5.1	5.1	5.1	62.0
64.0	4.8	4.6	4.6	4.6	4.5	4.5	64.0
66.0	4.3	4.1	4.1	4.1	4.1	4.1	66.0
68.0		3.6	3.8	3.7	3.7	3.7	68.0
70.0		3.4/68.7m	3.3	3.2	3.2	3.2	70.0
72.0			3.0/71.3m	2.8	2.8	2.8	72.0
74.0				2.4	2.4		74.0

※表中の太線で囲まれた部分は、ブーム等の強度によって定められた値です。

▶ ロング補助シーブ定格総荷重表 (35tフック装着)

(単位:t)

ブーム長さ 作業半径(m)	73.2	76.2	79.2	82.3	85.3	88.4	ブーム長さ 作業半径(m)
14.0	13.5/15.1m	13.5/15.7m					14.0
16.0	13.5	13.5	13.5/16.2m	13.5/16.7m	13.5/17.3m	13.5/17.8m	16.0
18.0	13.5	13.5	13.5	13.5	13.5	13.5	18.0
20.0	13.5	13.5	13.5	13.5	13.5	13.5	20.0
22.0	13.5	13.5	13.5	13.5	13.5	13.5	22.0
24.0	13.5	13.5	13.5	13.5	13.5	13.5	24.0
26.0	13.5	13.5	13.5	13.5	13.5	13.5	26.0
28.0	13.5	13.5	13.5	13.5	13.5	13.5	28.0
30.0	13.5	13.5	13.5	13.5	13.5	13.5	30.0
32.0	13.5	13.5	13.5	13.5	13.5	13.5	32.0
34.0	13.5	13.5	13.5	13.5	13.5	13.5	34.0
36.0	13.5	13.5	13.5	13.5	13.5	13.5	36.0
38.0	13.5	13.5	13.5	13.5	13.5	13.5	38.0
40.0	13.5	13.5	13.5	13.5	13.5	13.0	40.0
42.0	13.3	13.3	13.1	13.1	13.1	12.2	42.0
44.0	12.2	12.2	12.0	12.0	12.0	11.3	44.0
46.0	11.3	11.3	11.1	11.1	11.0	10.6	46.0
48.0	10.4	10.3	10.2	10.2	10.1	9.9	48.0
50.0	9.5	9.5	9.4	9.3	9.3	9.1	50.0
52.0	8.8	8.8	8.7	8.6	8.6	8.4	52.0
54.0	8.1	8.1	7.9	7.9	7.8	7.8	54.0
56.0	7.4	7.4	7.3	7.2	7.2	7.2	56.0
58.0	6.8	6.8	6.6	6.6	6.5	6.5	58.0
60.0	6.2	6.1	6.0	6.0	5.9	5.9	60.0
62.0	5.6	5.5	5.5	5.4	5.4	5.4	62.0
64.0	5.1	4.9	4.9	4.9	4.8	4.8	64.0
66.0	4.6	4.4	4.4	4.4	4.4	4.4	66.0
68.0		3.9	4.1	4.0	4.0	4.0	68.0
70.0		3.7/68.7m	3.6	3.5	3.5	3.5	70.0
72.0			3.3/71.3m	3.1	3.1	3.1	72.0
74.0				2.7	2.7	2.7	74.0

※表中の太線で囲まれた部分は、ブーム等の強度によって定められた値です。

▶ ロング補助シーブ定格総荷重表 (主ブームにフックなし)

(単位:t)

ブーム長さ 作業半径(m)	73.2	76.2	79.2	82.3	85.3	88.4	ブーム長さ 作業半径(m)
14.0	13.5/15.1m	13.5/15.7m					14.0
16.0	13.5	13.5	13.5/16.2m	13.5/16.7m	13.5/17.3m	13.5/17.8m	16.0
18.0	13.5	13.5	13.5	13.5	13.5	13.5	18.0
20.0	13.5	13.5	13.5	13.5	13.5	13.5	20.0
22.0	13.5	13.5	13.5	13.5	13.5	13.5	22.0
24.0	13.5	13.5	13.5	13.5	13.5	13.5	24.0
26.0	13.5	13.5	13.5	13.5	13.5	13.5	26.0
28.0	13.5	13.5	13.5	13.5	13.5	13.5	28.0
30.0	13.5	13.5	13.5	13.5	13.5	13.5	30.0
32.0	13.5	13.5	13.5	13.5	13.5	13.5	32.0
34.0	13.5	13.5	13.5	13.5	13.5	13.5	34.0
36.0	13.5	13.5	13.5	13.5	13.5	13.5	36.0
38.0	13.5	13.5	13.5	13.5	13.5	13.5	38.0
40.0	13.5	13.5	13.5	13.5	13.5	13.5	40.0
42.0	13.5	13.5	13.5	13.5	13.5	13.1	42.0
44.0	13.1	13.1	12.9	12.9	12.9	12.2	44.0
46.0	12.2	12.2	12.0	12.0	11.9	11.5	46.0
48.0	11.3	11.2	11.1	11.1	11.0	10.8	48.0
50.0	10.4	10.4	10.3	10.2	10.2	10.0	50.0
52.0	9.7	9.7	9.6	9.5	9.5	9.3	52.0
54.0	9.0	9.0	8.8	8.8	8.7	8.7	54.0
56.0	8.3	8.3	8.2	8.1	8.1	8.1	56.0
58.0	7.7	7.7	7.5	7.5	7.4	7.4	58.0
60.0	7.1	7.0	6.9	6.9	6.8	6.8	60.0
62.0	6.5	6.4	6.4	6.3	6.3	6.3	62.0
64.0	6.0	5.8	5.8	5.8	5.7	5.7	64.0
66.0	5.5/66.0m	5.3	5.3	5.3	5.3	5.3	66.0
68.0		4.8	5.0	4.9	4.9	4.9	68.0
70.0		4.6/68.7m	4.5	4.4	4.4	4.4	70.0
72.0			4.2/71.3m	4.0	4.0	4.0	72.0
74.0				3.6/74.0m	3.6	3.6	74.0
76.0					3.2	3.2	76.0
78.0					3.1/76.6m	2.9/78.0m	78.0

※表中の太線で囲まれた部分は、ブーム等の強度によって定められた値です。

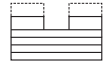

▶ ロング主ブーム定格総荷重表 (75.1tカウンタウエイト/カーボディウエイトなし)(オプション)

(単位:t)

ブーム長さ (m) 作業半径(m)	73.2	76.2	79.2	82.3	85.3	88.4	91.4	ブーム長さ (m) 作業半径(m)
14.0	37.5/14.4m	34.5/14.9m	32.6/15.4m					14.0
16.0	36.0	33.5	32.1	31.2	25.0/16.5m	25.0/17.0m	21.5/17.6m	16.0
18.0	34.4	31.9	30.6	29.6	25.0	25.0	21.2	18.0
20.0	32.9	30.4	29.1	28.2	25.0	24.1	20.0	20.0
22.0	29.2	29.1	27.9	26.9	25.0	23.0	18.9	22.0
24.0	25.8	25.7	25.6	25.5	25.0	22.0	17.8	24.0
26.0	23.0	22.9	22.8	22.7	22.7	21.1	16.9	26.0
28.0	20.6	20.5	20.4	20.4	20.4	20.3	16.0	28.0
30.0	18.6	18.5	18.4	18.4	18.4	18.3	15.3	30.0
32.0	16.9	16.8	16.7	16.7	16.6	16.6	14.5	32.0
34.0	15.4	15.3	15.2	15.2	15.1	15.1	13.8	34.0
36.0	14.1	14.0	13.9	13.9	13.8	13.8	13.1	36.0
38.0	13.0	12.9	12.7	12.7	12.7	12.6	12.5	38.0
40.0	12.0	11.8	11.7	11.7	11.6	11.6	11.6	40.0
42.0	11.0	10.9	10.8	10.8	10.7	10.7	10.6	42.0
44.0	10.2	10.1	10.0	9.9	9.9	9.8	9.8	44.0
46.0	9.5	9.3	9.2	9.2	9.1	9.1	9.0	46.0
48.0	8.8	8.7	8.5	8.5	8.4	8.4	8.3	48.0
50.0	8.2	8.0	7.9	7.9	7.8	7.8	7.7	50.0
52.0	7.6	7.5	7.3	7.3	7.2	7.2	7.1	52.0
54.0	7.1	6.9	6.8	6.8	6.7	6.6	6.6	54.0
56.0	6.6	6.5	6.3	6.3	6.2	6.2	6.1	56.0
58.0	6.2	6.0	5.9	5.8	5.7	5.7	5.6	58.0
60.0	5.8	5.6	5.4	5.4	5.2	5.2	5.1	60.0
62.0	5.4	5.2	5.0	4.9	4.8	4.7	4.6	62.0
64.0	5.0	4.8	4.6	4.5	4.4	4.3	4.2	64.0
66.0	4.8/64.9m	4.4	4.2	4.1	4.0	3.9	3.8	66.0
68.0		4.1/67.5m	3.8	3.7	3.6	3.5	3.4	68.0
70.0			3.5	3.4	3.2	3.2	3.1	70.0
72.0			3.5/70.2m	3.1	2.9	2.8	2.7	72.0
74.0				3.0/72.8m	2.6	2.5	2.4	74.0
76.0					2.4/74.5m			76.0

※表中の太線で囲まれた部分は、ブーム等の強度によって定められた値です。

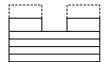

▶ ロング補助シーブ付主ブーム定格総荷重表 (75.1tカウンタウエイト/カーボディウエイトなし)(オプション)

(単位:t)

ブーム長さ (m) 作業半径(m)	73.2	76.2	79.2	82.3	85.3	88.4	ブーム長さ (m) 作業半径(m)
14.0	36.6/14.4m	33.6/14.9m	31.7/15.4m				14.0
16.0	35.1	32.6	31.2	30.3	24.1/16.5m	24.1/17.0m	16.0
18.0	33.5	31.0	29.7	28.7	24.1	24.1	18.0
20.0	32.0	29.5	28.2	27.3	24.1	23.2	20.0
22.0	28.3	28.2	27.0	26.0	24.1	22.1	22.0
24.0	24.9	24.8	24.7	24.6	24.1	21.1	24.0
26.0	22.1	22.0	21.9	21.8	21.8	20.2	26.0
28.0	19.7	19.6	19.5	19.5	19.5	19.4	28.0
30.0	17.7	17.6	17.5	17.5	17.5	17.4	30.0
32.0	16.0	15.9	15.8	15.8	15.7	15.7	32.0
34.0	14.5	14.4	14.3	14.3	14.2	14.2	34.0
36.0	13.2	13.1	13.0	13.0	12.9	12.9	36.0
38.0	12.1	12.0	11.8	11.8	11.8	11.7	38.0
40.0	11.1	10.9	10.8	10.8	10.7	10.7	40.0
42.0	10.1	10.0	9.9	9.9	9.8	9.8	42.0
44.0	9.3	9.2	9.1	9.0	9.0	8.9	44.0
46.0	8.6	8.4	8.3	8.3	8.2	8.2	46.0
48.0	7.9	7.8	7.6	7.6	7.5	7.5	48.0
50.0	7.3	7.1	7.0	7.0	6.9	6.9	50.0
52.0	6.7	6.6	6.4	6.4	6.3	6.3	52.0
54.0	6.2	6.0	5.9	5.9	5.8	5.7	54.0
56.0	5.7	5.6	5.4	5.4	5.3	5.3	56.0
58.0	5.3	5.1	5.0	4.9	4.8	4.8	58.0
60.0	4.9	4.7	4.5	4.5	4.3	4.3	60.0
62.0	4.5	4.3	4.1	4.0	3.9	3.8	62.0
64.0	4.1	3.9	3.7	3.6	3.5	3.4	64.0
66.0	3.9/64.9m	3.5	3.3	3.2	3.1	3.0	66.0
68.0		3.2/67.5m	2.9	2.8	2.7	2.6	68.0
70.0			2.6	2.5			70.0
72.0			2.6/70.2m				72.0

※表中の太線で囲まれた部分は、ブーム等の強度によって定められた値です。



▶ ロング補助シーブ定格総荷重表 (75.1カウンタウエイト/カーボディウエイトなし、65tフック装着)(オプション)

(単位:t)

ブーム長さ (m) 作業半径(m)	73.2	76.2	79.2	82.3	85.3	88.4	ブーム長さ (m) 作業半径(m)
14.0	13.5/15.1m	13.5/15.7m					14.0
16.0	13.5	13.5	13.5/16.2m	13.5/16.7m	13.5/17.3m	13.5/17.8m	16.0
18.0	13.5	13.5	13.5	13.5	13.5	13.5	18.0
20.0	13.5	13.5	13.5	13.5	13.5	13.5	20.0
22.0	13.5	13.5	13.5	13.5	13.5	13.5	22.0
24.0	13.5	13.5	13.5	13.5	13.5	13.5	24.0
26.0	13.5	13.5	13.5	13.5	13.5	13.5	26.0
28.0	13.5	13.5	13.5	13.5	13.5	13.5	28.0
30.0	13.5	13.5	13.5	13.5	13.5	13.5	30.0
32.0	13.5	13.5	13.5	13.5	13.5	13.5	32.0
34.0	13.5	13.5	13.5	13.5	13.5	13.5	34.0
36.0	12.6	12.5	12.4	12.4	12.3	12.3	36.0
38.0	11.5	11.4	11.2	11.2	11.2	11.1	38.0
40.0	10.5	10.3	10.2	10.2	10.1	10.1	40.0
42.0	9.5	9.4	9.3	9.3	9.2	9.2	42.0
44.0	8.7	8.6	8.5	8.4	8.4	8.3	44.0
46.0	8.0	7.8	7.7	7.7	7.6	7.6	46.0
48.0	7.3	7.2	7.0	7.0	6.9	6.9	48.0
50.0	6.7	6.5	6.4	6.4	6.3	6.3	50.0
52.0	6.1	6.0	5.8	5.8	5.7	5.7	52.0
54.0	5.6	5.4	5.3	5.3	5.2	5.1	54.0
56.0	5.1	5.0	4.8	4.8	4.7	4.7	56.0
58.0	4.7	4.5	4.4	4.3	4.2	4.2	58.0
60.0	4.3	4.1	3.9	3.9	3.7	3.7	60.0
62.0	3.9	3.7	3.5	3.4	3.3	3.2	62.0
64.0	3.5	3.3	3.1	3.0	2.9	2.8	64.0
66.0	3.1	2.9	2.7	2.6	2.5	2.4	66.0
68.0		2.5					68.0
70.0		2.4/68.7m					70.0

※表中の太線で囲まれた部分は、ブーム等の強度によって定められた値です。



▶ ロング補助シーブ定格総荷重表 (75.1カウンタウエイト/カーボディウエイトなし、35tフック装着)(オプション)

(単位:t)

ブーム長さ (m) 作業半径(m)	73.2	76.2	79.2	82.3	85.3	88.4	ブーム長さ (m) 作業半径(m)
14.0	13.5/15.1m	13.5/15.7m					14.0
16.0	13.5	13.5	13.5/16.2m	13.5/16.7m	13.5/17.3m	13.5/17.8m	16.0
18.0	13.5	13.5	13.5	13.5	13.5	13.5	18.0
20.0	13.5	13.5	13.5	13.5	13.5	13.5	20.0
22.0	13.5	13.5	13.5	13.5	13.5	13.5	22.0
24.0	13.5	13.5	13.5	13.5	13.5	13.5	24.0
26.0	13.5	13.5	13.5	13.5	13.5	13.5	26.0
28.0	13.5	13.5	13.5	13.5	13.5	13.5	28.0
30.0	13.5	13.5	13.5	13.5	13.5	13.5	30.0
32.0	13.5	13.5	13.5	13.5	13.5	13.5	32.0
34.0	13.5	13.5	13.5	13.5	13.5	13.5	34.0
36.0	12.9	12.8	12.7	12.7	12.6	12.6	36.0
38.0	11.8	11.7	11.5	11.5	11.5	11.4	38.0
40.0	10.8	10.6	10.5	10.5	10.4	10.4	40.0
42.0	9.8	9.7	9.6	9.6	9.5	9.5	42.0
44.0	9.0	8.9	8.8	8.7	8.7	8.6	44.0
46.0	8.3	8.1	8.0	8.0	7.9	7.9	46.0
48.0	7.6	7.5	7.3	7.3	7.2	7.2	48.0
50.0	7.0	6.8	6.7	6.7	6.6	6.6	50.0
52.0	6.4	6.3	6.1	6.1	6.0	6.0	52.0
54.0	5.9	5.7	5.6	5.6	5.5	5.4	54.0
56.0	5.4	5.3	5.1	5.1	5.0	5.0	56.0
58.0	5.0	4.8	4.7	4.6	4.5	4.5	58.0
60.0	4.6	4.4	4.2	4.2	4.0	4.0	60.0
62.0	4.2	4.0	3.8	3.7	3.6	3.5	62.0
64.0	3.8	3.6	3.4	3.3	3.2	3.1	64.0
66.0	3.4	3.2	3.0	2.9	2.8	2.7	66.0
68.0		2.8	2.6	2.5	2.4/67.0m		68.0
70.0		2.7/68.7m					70.0

※表中の太線で囲まれた部分は、ブーム等の強度によって定められた値です。

200t

KOBELCO 7200G-2

クローラクレーン

yonehara



▶ ロング補助シーブ定格総荷重表 (75.1tカウンタウエイト/カーボディウエイトなし、主フックなし)(オプション)

(単位:t)

ブーム長さ 作業半径(m)	73.2	76.2	79.2	82.3	85.3	88.4	ブーム長さ 作業半径(m)
14.0	135/15.1m	135/15.7m					14.0
16.0	13.5	13.5	135/16.2m	135/16.7m	135/17.3m	135/17.8m	16.0
18.0	13.5	13.5	13.5	13.5	13.5	13.5	18.0
20.0	13.5	13.5	13.5	13.5	13.5	13.5	20.0
22.0	13.5	13.5	13.5	13.5	13.5	13.5	22.0
24.0	13.5	13.5	13.5	13.5	13.5	13.5	24.0
26.0	13.5	13.5	13.5	13.5	13.5	13.5	26.0
28.0	13.5	13.5	13.5	13.5	13.5	13.5	28.0
30.0	13.5	13.5	13.5	13.5	13.5	13.5	30.0
32.0	13.5	13.5	13.5	13.5	13.5	13.5	32.0
34.0	13.5	13.5	13.5	13.5	13.5	13.5	34.0
36.0	13.5	13.5	13.5	13.5	13.5	13.5	36.0
38.0	12.7	12.6	12.4	12.4	12.4	12.3	38.0
40.0	11.7	11.5	11.4	11.4	11.3	11.3	40.0
42.0	10.7	10.6	10.5	10.5	10.4	10.4	42.0
44.0	9.9	9.8	9.7	9.6	9.6	9.5	44.0
46.0	9.2	9.0	8.9	8.9	8.8	8.8	46.0
48.0	8.5	8.4	8.2	8.2	8.1	8.1	48.0
50.0	7.9	7.7	7.6	7.6	7.5	7.5	50.0
52.0	7.3	7.2	7.0	7.0	6.9	6.9	52.0
54.0	6.8	6.6	6.5	6.5	6.4	6.3	54.0
56.0	6.3	6.2	6.0	6.0	5.9	5.9	56.0
58.0	5.9	5.7	5.6	5.5	5.4	5.4	58.0
60.0	5.5	5.3	5.1	5.1	4.9	4.9	60.0
62.0	5.1	4.9	4.7	4.6	4.5	4.4	62.0
64.0	4.7	4.5	4.3	4.2	4.1	4.0	64.0
66.0	4.3	4.1	3.9	3.8	3.7	3.6	66.0
68.0		3.7	3.5	3.4	3.3	3.2	68.0
70.0		3.6/68.7m	3.2	3.1	2.9	2.9	70.0
72.0			3.0/71.3m	2.8	2.6	2.5	72.0
74.0				2.5			74.0

※表中の太線で囲まれた部分は、ブーム等の強度によって定められた値です。

200t

KOBELCO
クローラクレーン

7200G-2

yonehara

ラフティングタワー

全体図(単位: mm)

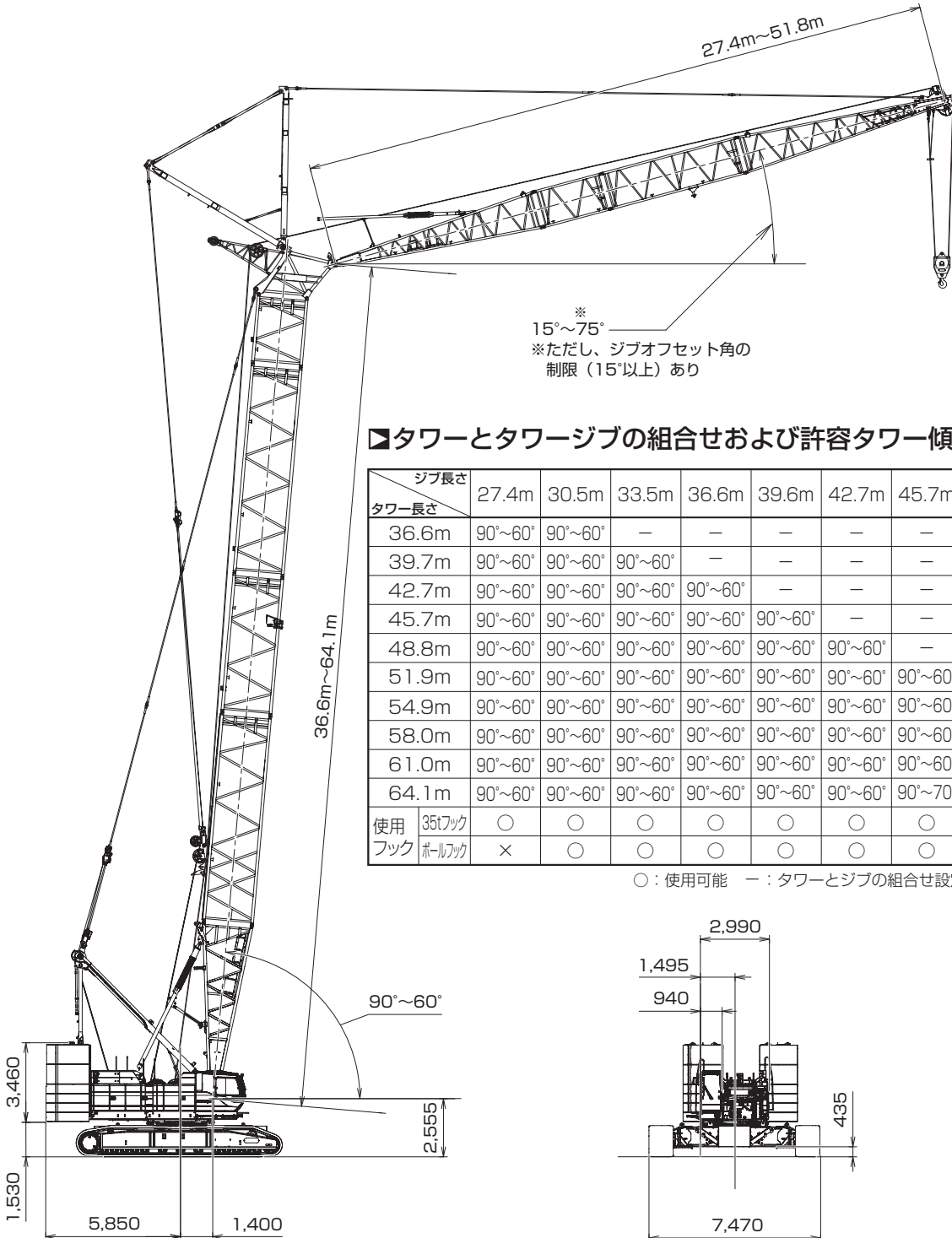

タワーとタワージブの組合せおよび許容タワー傾斜角度

ジブ長さ タワー長さ	27.4m	30.5m	33.5m	36.6m	39.6m	42.7m	45.7m	48.8m	51.8m	敷板	側方自立
36.6m	90°~60°	90°~60°	—	—	—	—	—	—	—	不要	可
39.7m	90°~60°	90°~60°	90°~60°	—	—	—	—	—	—	不要	可
42.7m	90°~60°	90°~60°	90°~60°	90°~60°	—	—	—	—	—	不要	可
45.7m	90°~60°	90°~60°	90°~60°	90°~60°	90°~60°	—	—	—	—	不要	可
48.8m	90°~60°	90°~60°	90°~60°	90°~60°	90°~60°	90°~60°	—	—	—	不要	可
51.9m	90°~60°	90°~60°	90°~60°	90°~60°	90°~60°	90°~60°	90°~60°	—	—	不要	可
54.9m	90°~60°	90°~60°	90°~60°	90°~60°	90°~60°	90°~60°	90°~60°	90°~60°	—	不要	可
58.0m	90°~60°	90°~60°	90°~60°	90°~60°	90°~60°	90°~60°	90°~60°	90°~60°	90°~70°	不要	可
61.0m	90°~60°	90°~60°	90°~60°	90°~60°	90°~60°	90°~60°	90°~60°	90°~60°	90°~70°	不要	不可
64.1m	90°~60°	90°~60°	90°~60°	90°~60°	90°~60°	90°~60°	90°~70°	90°~70°	90°~70°	必要	不可
使用フック	35tフック	○	○	○	○	○	○	○	○	✕	
フック	ホルフック	×	○	○	○	○	○	○	○		

○: 使用可能 —: タワーとジブの組合せ設定なし ×: つり上能力設定なし

■タワー構成

- ※印は、これより短いタワーの組立可能な構成を示します。
- 9.1Aは、クローラクレーンの中間ブームとしても使用できます。
- 下部ブーム直近の9.1m中間ブームには、9.1Aを使用してください。
- 使用するガイラインの径はφ38mmです。

中間タワーの種類		
記号	タワー長さ	備考
3.0	3.0m	クレーンおよびタワー共用
6.1	6.1m	クレーンおよびタワー共用
9.1	9.1m	クレーンおよびタワー共用
9.1A	9.1m	タワー専用 (クレーンに兼用可能)

タワー長さ m (ft.)	タワー構成
36.6 (120)	
39.7 (130)	<p>※</p>
42.7 (140)	<p>※</p>
45.8 (150)	<p>※</p>
48.8 (160)	<p>※</p>
51.9 (170)	<p>※</p>
54.9 (180)	<p>※</p>
58.0 (190)	<p>※</p>
61.0 (200)	<p>※</p>
64.1 (210)	<p>※</p>

■タワージブ構成

- ※印は、これより短いタワージブの組立可能な構成を示します。
- 印は、ケーブルローラー取付位置を示します。
- 使用するガイラインの径はφ38mmです。

中間タワージブの種類		
記号	タワージブ長さ	備考
3.0A	3.0m	中継ジブ
3.0	3.0m	ロング中間ブーム共用
6.1	6.1m	ロング中間ブーム共用
9.1	9.1m	ロング中間ブーム共用

タワー長さ m (ft.)	タワージブ構成
27.4 (90)	
30.5 (100)	<p>※</p>
33.5 (110)	<p>※</p>
36.6 (120)	<p>※</p>
39.6 (130)	<p>※</p>
42.7 (140)	<p>※</p>
45.7 (150)	<p>※</p>
48.8 (160)	<p>※</p>
51.8 (170)	<p>※</p>

■定格総荷重

- 定格総荷重とは、水平堅土上における転倒荷重の78%以内で、フックブロック、玉掛用ワイヤロープ等のつり具の質量を含んだ値です。
- 作業半径とはクレーン旋回中心よりつり上荷重の重心までの水平距離を意味します。
- 実際につり上げ得る荷重は定格総荷重から（主フック+玉掛用ワイヤロープ等のつり具）の質量を差し引いた値になります。ただし、中間ブームにブームネスティングローラ（オプション）が取付いた状態で作業する場合の定格総荷重の最大値は、使用するフックの呼称容量から使用するフック質量とブームネスティングローラ質量（下表）を差し引いた値とします。

タワー

タワー長さ(m)	36.6	39.7	42.7	45.8	48.8	51.9	54.9	58.0	61.0	64.1
差し引く値(t)	0.1	0.1	0.2	0.2	0.2	0.2	0.2	0.2	0.2	0.2

- 定格総荷重をつる場合にも風の影響、地盤の状態、作業速度その他安全作業に有害な状況がある時はオペレータは荷重の軽減、作業速度を遅くするなど状況に応じた判断をする責任があります。
 - 表中の空欄の個所では作業を行うことができません。
 - クレーン作業中はガントリを最高位置に立ててください。
 - すべてのタワー（ジブ）長さにおける中間タワーブーム（ジブ）の構成は取扱説明書の指示を厳守してください。
 - ジブ長さ27.4mにてボールフックの使用はできません。
 - 64.1mタワーの自立、降下の際には、クローラの前端に敷板（ブロック）を敷いて下さい。
- △ 操作ミスなどによるつり荷の落下を防ぐため、クレーン作業では自由降下（フリーフォール）作業は行わないでください。
- 巻上げロープ巻掛本数に対する最大巻上荷重とフックの質量

フック呼称	35t	ボールフック
最大巻上荷重 (t)	1本掛	13.5
	2本掛	25.0
フック質量	0.90t	0.45t

※ジブ長さ27.4mでのボールフックの使用はできません。

■フック巻上限界 (単位:m)

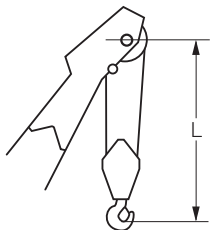

使用フック	L
35tフック	4.2

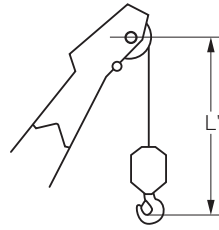

使用フック	L'
ボールフック	4.0

■タワー長さ 36.6m

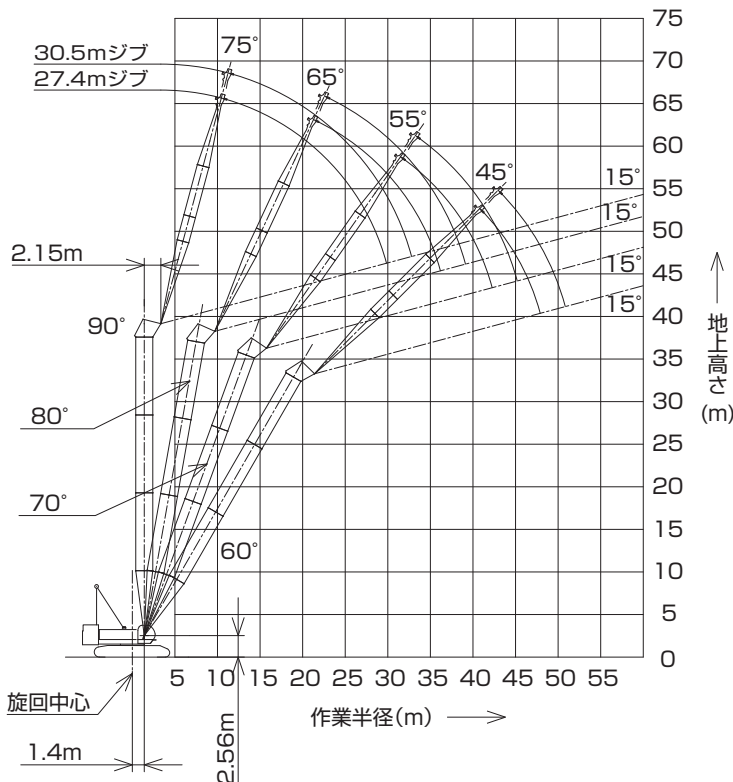

(単位:t)

タワー長さm	36.6							タワー長さm	
ジブ長さm	27.4				30.5			ジブ長さm	
タワー角度	90°	80°	70°	60°	90°	80°	70°	60°	タワー角度
作業半径 (m)	10.0	25.0/10.9m			25/11.7m				10.0
	12.0	25.0			25.0				12.0
	14.0	25.0			25.0				14.0
	16.0	25.0			25.0				16.0
	18.0	25.0			24.2				18.0
	20.0	24.2	23.4/21.7m		23.5				20.0
	22.0	23.2	23.2		22.7	21.9/23.0m			22.0
	24.0	21.0	21.0		21.0	21.0			24.0
	26.0	18.6	18.6		18.6	18.6			26.0
	28.0	16.0	16.8		16.7	16.7			28.0
	30.0	11.2/29.9m	15.2	14.1/31.9m	15.1	15.1			30.0
	32.0		14.0	14.0	12.0	13.9	13.0/33.7m		32.0
	34.0		12.8	12.8	10.6/32.8m	12.7	12.7		34.0
	36.0		11.8	11.8		11.7	11.7		36.0
	38.0		11.8/36.2m	11.1		11.0	11.0		38.0
	40.0			10.4	10.0/41.2m	10.6/39.2m	10.3		40.0
42.0			9.7	9.7		9.6	9.2/43.3m	42.0	
44.0			9.6/42.3m	9.1		9.0	9.0	44.0	
46.0				8.6		8.7/45.2m	8.5	46.0	
48.0				8.2			8.1	48.0	
50.0				8.2/47.9m			7.7	50.0	
52.0							7.6/50.8m	52.0	

※表中の太線で囲まれた部分は、ブーム等の強度によって定められた値です。

▶タワー長さ 39.7m

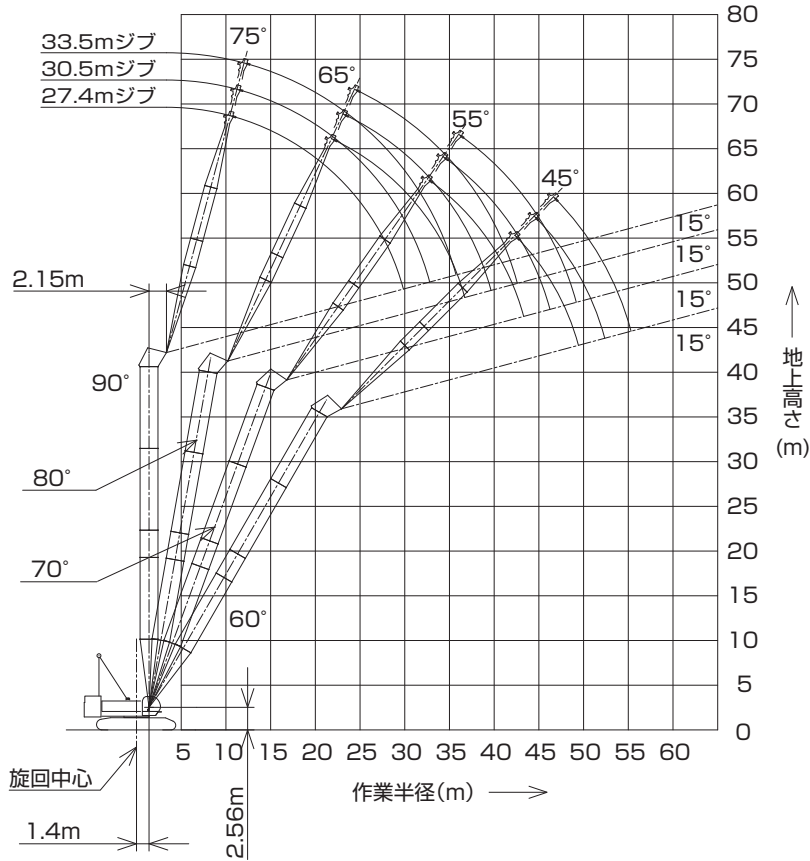

(単位:t)

タワー長さm	39.7												タワー長さm
ジブ長さm	27.4				30.5				33.5				ジブ長さm
タワー角度	90°	80°	70°	60°	90°	80°	70°	60°	90°	80°	70°	60°	タワー角度
作業半径 (m)	10.0	25.0/10.9m			25.0/11.7m								10.0
	12.0	25.0			25.0				25.0/12.5m				12.0
	14.0	25.0			25.0				25.0				14.0
	16.0	25.0			25.0				24.2				16.0
	18.0	25.0			24.2				23.4				18.0
	20.0	24.2			23.5				22.6				20.0
	22.0	23.2	22.8/22.3m		22.7	21.4/23.6m			21.8				22.0
	24.0	20.9	20.9		21.0	20.9			21.0	20.2/24.8m			24.0
	26.0	18.5	18.6		18.6	18.6			18.8	18.6			26.0
	28.0	16.1	16.8		16.7	16.7			16.7	16.7			28.0
	30.0	11.2/29.9m	15.2		15.1	15.1			15.3	15.1			30.0
	32.0		14.0	13.4/33.0m	12.0	13.9			14.0	13.9			32.0
	34.0		12.8	12.8	10.6/32.8m	12.7	12.4/34.7m		12.0	12.7			34.0
	36.0		11.8	11.8		11.7	11.7		9.2/35.8m	11.7	11.5/36.5m		36.0
	38.0		11.5/36.7m	11.1		11.0	11.0			11.0	11.0		38.0
	40.0			10.4		10.4/39.7m	10.3			10.2	10.3		40.0
	42.0			9.7	9.5/42.7m		9.6			9.6	9.6		42.0
44.0			9.3/43.3m	9.1		9.0	8.7/44.9m		9.4/42.6m	9.0		44.0	
46.0				8.6		8.5	8.5			8.4	8.2/47.0m	46.0	
48.0				8.2		8.4/46.3m	8.1			8.0	8.0	48.0	
50.0				8.0/49.4m			7.7			7.7/49.2m	7.6	50.0	
52.0							7.3				7.2	52.0	
54.0							7.2/52.4m				6.8	54.0	
56.0											6.6/55.3m	56.0	

*表中の太線で囲まれた部分は、ブーム等の強度によって定められた値です。

200t

KOBELCO
クローラクレーン

7200G-2

yonehara

▶タワー長さ 42.7m

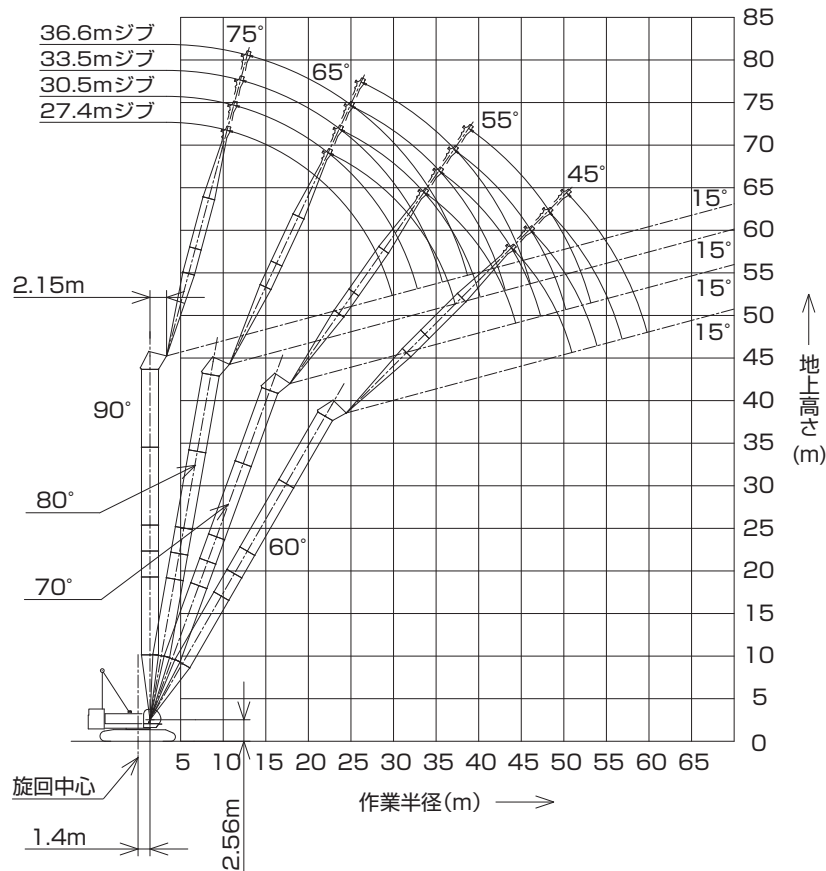

(単位:t)

タワー長さm	42.7																タワー長さm
ジブ長さm	27.4				30.5				33.5				36.6				ジブ長さm
タワー角度	90°	80°	70°	60°	90°	80°	70°	60°	90°	80°	70°	60°	90°	80°	70°	60°	タワー角度
作業半径 (m)	10.0	25.0/10.9m			25.0/11.7m												10.0
	12.0	25.0			25.0				25.0/12.5m				23.9/13.3m				12.0
	14.0	25.0			25.0				25.0				23.6				14.0
	16.0	25.0			25.0				24.2				22.9				16.0
	18.0	25.0			24.2				23.4				22.2				18.0
	20.0	24.2			23.5				22.6				21.4				20.0
	22.0	23.2	22.3/22.8m		22.7				21.8				20.7				22.0
	24.0	20.9	20.9		21.0	20.9/24.1m			21.0	19.6/25.4m			19.9				24.0
	26.0	18.5	18.6		18.6	18.6			18.8	18.6			18.8	18.2/26.7m			26.0
	28.0	16.3	16.8		16.7	16.7			16.7	16.7			16.8	16.7			28.0
	30.0	11.3/29.9m	15.2		15.1	15.1			15.3	15.1			15.2	15.0			30.0
	32.0		14.0		12.0	13.9			14.0	13.9			14.0	13.8			32.0
	34.0		12.8	12.8/34.0m	10.6/32.8m	12.7	11.8/35.8m		12.1	12.7			12.8	12.6			34.0
	36.0		11.8	11.8		11.7	11.7		9.2/35.8m	11.7			11.7	11.6			36.0
	38.0		11.4/37.3m	11.1		11.0	11.0			11.0	11.0/38.0m		9.3	10.9	10.4/39.3m		38.0
	40.0			10.4		10.3	10.3			10.2	10.3		8.7/38.7m	10.1	10.1		40.0
	42.0			9.7		10.2/40.2m	9.6			9.6	9.6			9.5	9.5		42.0
	44.0			9.1	9.0/44.2m		9.0			9.3/43.2m	9.0			8.9	8.9		44.0
	46.0			8.9/44.4m	8.6		8.5	8.4/46.4m		8.4				8.4	8.3		46.0
	48.0				8.2		8.2/47.3m	8.1		7.9	7.9/48.5m			8.3/46.1m	7.8		48.0
50.0				7.8			7.7		7.5	7.5/50.2m			7.4	7.3/50.7m		50.0	
52.0				7.6/51.0m			7.3						7.2	7.0	7.1	52.0	
54.0							6.9/53.9m						6.8		6.7/53.2m	6.7	54.0
56.0													6.4			6.3	56.0
58.0													6.3/56.8m			6.0	58.0
60.0																5.7/59.8m	60.0

※表中の太線で囲まれた部分は、ブーム等の強度によって定められた値です。

▶タワー長さ 45.8m

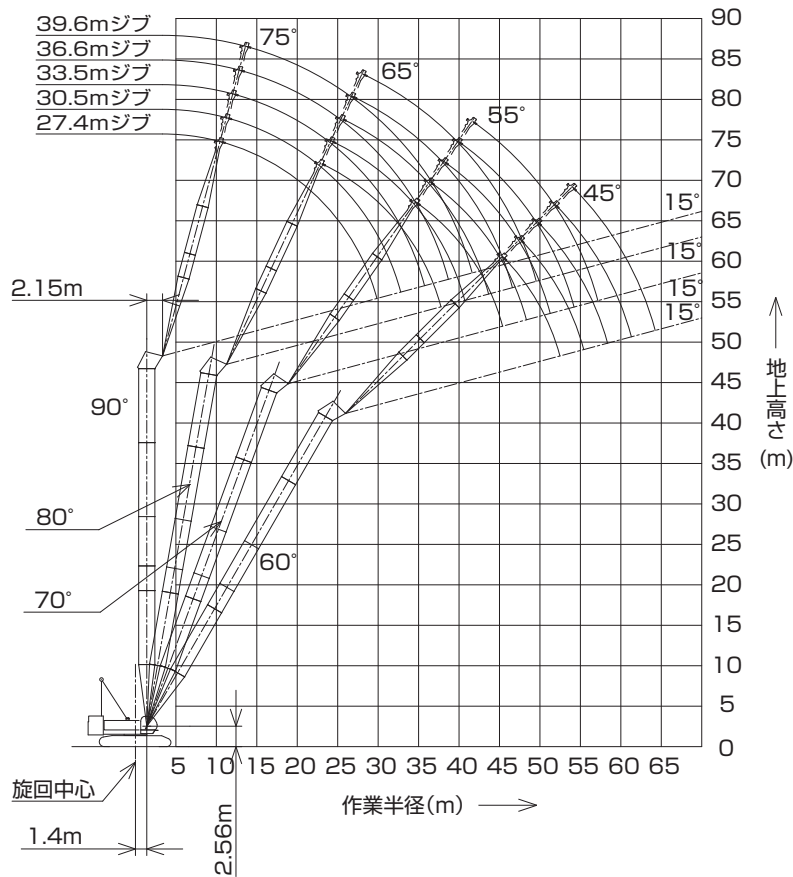

(単位:t)

タワー長さm	45.8																タワー長さm					
ジブ長さm	27.4				30.5				33.5				36.6				39.6				ジブ長さm	
タワー角度	90°	80°	70°	60°	90°	80°	70°	60°	90°	80°	70°	60°	90°	80°	70°	60°	90°	80°	70°	60°	タワー角度	
10.0	25.0/10.9m				25.0/11.7m																10.0	
12.0	25.0				25.0				25.0/12.5m				23.9/13.3m								12.0	
14.0	25.0				25.0				25.0				23.6				22.0/14.1m				14.0	
16.0	25.0				25.0				24.2				22.9				21.4				16.0	
18.0	25.0				24.2				23.4				22.2				20.8				18.0	
20.0	24.2				23.5				22.6				21.4				20.2				20.0	
22.0	23.2	21.7/23.3m			22.7				21.8				20.7				19.6				22.0	
24.0	20.9	20.9			21.0	20.3/24.5m			21.0	18.7/25.9m			19.9				19.0				24.0	
26.0	18.5	18.6			18.6	18.6			18.8	18.6			18.8	17.6/27.2m			18.3				26.0	
28.0	16.3	16.8			16.7	16.7			16.7	16.7			16.8	16.7			16.8	16.3/28.5m			28.0	
30.0	11.3/23.9m	15.2			15.1	15.1			15.3	15.1			15.2	15.0			15.2	14.9			30.0	
32.0		14.0			12.0	13.9			14.0	13.9			14.0	13.8			14.0	13.7			32.0	
34.0		12.8	12.3/35.0m		10.6/32.8m	12.7			12.1	12.7			12.8	12.6			12.8	12.5			34.0	
36.0		11.8	11.8			11.7	11.5/36.8m		11.7				11.6	11.6			11.8	11.5			36.0	
38.0		11.2/37.8m	11.1			11.0	11.0		11.0	10.9/38.5m			9.3	10.9			10.8	10.8			38.0	
40.0			10.4			10.3	10.3		10.2	10.3			8.7/38.7m	10.1	10.1/40.3m		9.3	10.0			40.0	
42.0			9.7			10.1/40.7m	9.6		9.6	9.6				9.5	9.5		7.7/41.7m	9.4	9.4/42.0m		42.0	
44.0			9.1	8.6/45.8m			9.0		9.1/43.7m	9.0			8.9	8.9			8.8	8.7			44.0	
46.0			8.8/45.4m	8.6			8.5	8.1/47.9m		8.4			8.4	8.3			8.2	8.1			46.0	
48.0				8.2			8.1	8.1		7.9				8.2/46.6m	7.8		7.6	7.6			48.0	
50.0				7.8			8.1/48.3m	7.7		7.5	7.6/50.1m				7.4		7.2/49.6m	7.2			50.0	
52.0				7.4				7.3		7.3/51.3m	7.2				7.0	7.0/52.2m		6.8			52.0	
54.0				7.3/52.5m				6.9			6.8				6.6	6.7		6.4	6.3/54.4m		54.0	
56.0								6.7/55.4m			6.4				6.6/54.2m	6.3		6.1	6.1		56.0	
58.0											6.1				6.0			5.9/57.2m	5.8		58.0	
60.0											6.0/58.4m				5.7				5.5		60.0	
62.0															5.5/61.3m					5.3	62.0	
64.0																					5.1	64.0
66.0																					5.0/64.3m	66.0

※表中の太線で囲まれた部分は、ブーム等の強度によって定められた値です。

▶タワー長さ 48.8m

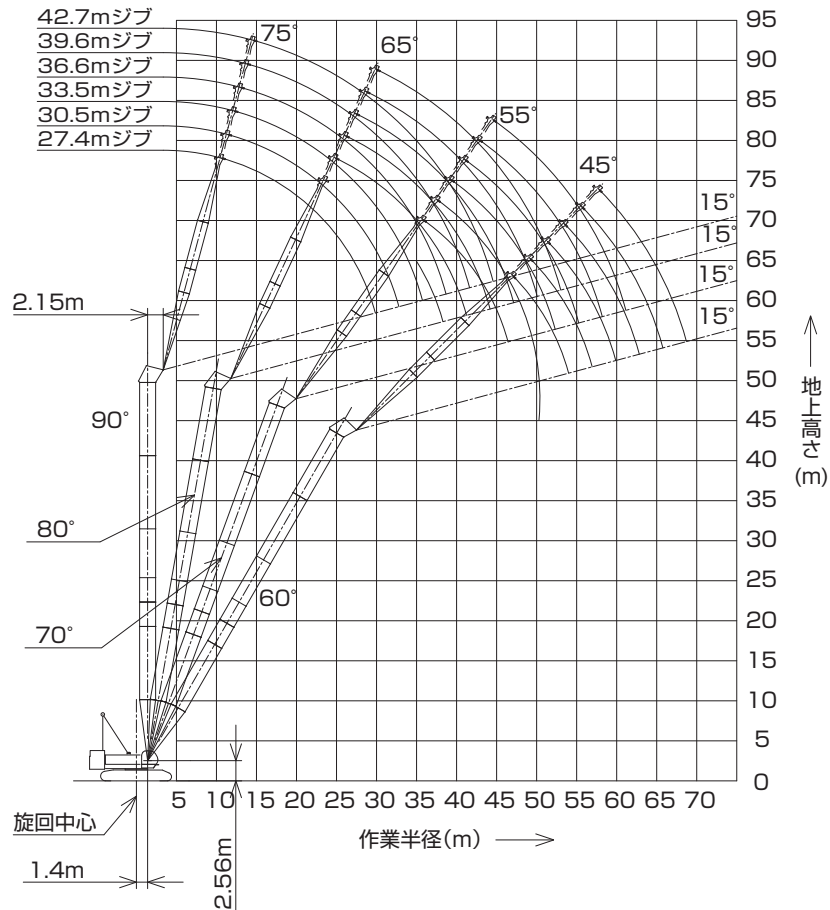

(単位:t)

タワー長さm	48.8								タワー長さm
ジブ長さm	27.4				30.5				ジブ長さm
タワー角度	90°	80°	70°	60°	90°	80°	70°	60°	タワー角度
作業半径 (m)	10.0	25.0/10.9m			25.0/11.7m				10.0
	12.0	25.0			25.0				12.0
	14.0	25.0			25.0				14.0
	16.0	25.0			25.0				16.0
	18.0	25.0			24.2				18.0
	20.0	24.2			23.5				20.0
	22.0	23.2	21.2/23.9m		22.7				22.0
	24.0	20.9	20.9		21.0	19.7/25.1m			24.0
	26.0	18.5	18.6		18.6	18.6			26.0
	28.0	16.3	16.8		16.7	16.7			28.0
	30.0	11.3/29.9m	15.2		15.1	15.1			30.0
	32.0		14.0		12.0	13.9			32.0
	34.0		12.8		10.6/32.8m	12.7			34.0
	36.0		11.8	11.8/36.1m		11.7	11.1/37.8m		36.0
	38.0		11.1	11.1		11.0	11.0		38.0
	40.0		11.0/38.3m	10.4		10.3	10.3		40.0
	42.0			9.7		9.9/41.3m	9.6		42.0
	44.0			9.1			9.0		44.0
	46.0			8.6	8.3/47.3m		8.5		46.0
	48.0			8.5/46.4m	8.2		8.0	7.8/49.4m	48.0
50.0				7.8		7.7/49.4m	7.7	50.0	
52.0				7.4			7.3	52.0	
54.0				7.0/54.0m			6.9	54.0	
56.0							6.5	56.0	
58.0							6.4/56.9m	58.0	

※表中の太線で囲まれた部分は、ブーム等の強度によって定められた値です。

200t

KOBELCO 7200G-2

クローラクレーン

yonehara

(単位:t)

タワー長さm	48.8								タワー長さm
ジブ長さm	33.5				36.6				ジブ長さm
タワー角度	90°	80°	70°	60°	90°	80°	70°	60°	タワー角度
12.0	25.0/12.5m				23.9/13.3m				12.0
14.0	25.0				23.6				14.0
16.0	24.2				22.9				16.0
18.0	23.4				22.2				18.0
20.0	22.6				21.4				20.0
22.0	21.8				20.7				22.0
24.0	21.0				19.9				24.0
26.0	18.8	18.4/26.4m			18.8	17.0/27.7m			26.0
28.0	16.7	16.7			16.8	16.7			28.0
30.0	15.3	15.1			15.2	15.0			30.0
32.0	14.0	13.9			14.0	13.8			32.0
34.0	12.1	12.7			12.8	12.6			34.0
36.0	9.2/35.8m	11.7			11.6	11.6			36.0
38.0		11.0	10.3/39.6m		9.3	10.9			38.0
40.0		10.2	10.2		8.7/38.7m	10.1	9.6/41.3m		40.0
42.0		9.6	9.5			9.5	9.4		42.0
44.0		8.9	8.9			8.9	8.8		44.0
46.0		8.9/44.2m	8.4			8.4	8.3		46.0
48.0			7.9			8.1/47.2m	7.8		48.0
50.0			7.5	7.3/51.6m			7.4		50.0
52.0			7.1	7.2			7.0	6.8/53.7m	52.0
54.0			7.1/52.3m	6.8			6.6	6.7	54.0
56.0				6.4			6.4/55.3m	6.3	56.0
58.0				6.1				6.0	58.0
60.0				5.8/59.9m				5.7	60.0
62.0								5.4	62.0
64.0								5.3/62.8m	64.0

※表中の太線で囲まれた部分は、ブーム等の強度によって定められた値です。

(単位:t)

タワー長さm	48.8								タワー長さm
ジブ長さm	39.6				42.7				ジブ長さm
タワー角度	90°	80°	70°	60°	90°	80°	70°	60°	タワー角度
14.0	22.0/14.1m				20.0/14.9m				14.0
16.0	21.4				19.7				16.0
18.0	20.8				19.2				18.0
20.0	20.2				18.6				20.0
22.0	19.6				18.1				22.0
24.0	19.0				17.5				24.0
26.0	18.3				17.0				26.0
28.0	16.8	15.8/29.0m			16.5				28.0
30.0	15.2	14.9			15.2	14.7/30.3m			30.0
32.0	14.0	13.7			14.0	13.6			32.0
34.0	12.8	12.5			12.8	12.4			34.0
36.0	11.8	11.5			11.8	11.4			36.0
38.0	10.8	10.8			10.9	10.6			38.0
40.0	9.3	10.0			9.8	9.8			40.0
42.0	7.7/41.7m	9.4	9.0/43.1m		8.9	9.2			42.0
44.0		8.8	8.7		7.2	8.6	8.3/44.8m		44.0
46.0		8.2	8.1		6.8/44.6m	8.0	7.9		46.0
48.0		7.6	7.6			7.4	7.4		48.0
50.0		7.2	7.2			7.0	7.0		50.0
52.0		7.1/50.1m	6.8			6.6	6.6		52.0
54.0			6.4	6.1/55.9m		6.4/53.0m	6.2		54.0
56.0			6.1	6.1			5.9		56.0
58.0			5.8	5.8			5.6	5.6/58.1m	58.0
60.0			5.8/58.2m	5.5			5.4	5.4	60.0
62.0				5.3			5.3/61.2m	5.2	62.0
64.0				5.1				5.0	64.0
66.0				4.9/65.8m				4.8	66.0
68.0								4.6	68.0
70.0								4.5/68.7m	70.0

※表中の太線で囲まれた部分は、ブーム等の強度によって定められた値です。

200t

KOBELCO 7200G-2

クローラクレーン

yonehara

▶タワー長さ 51.9m

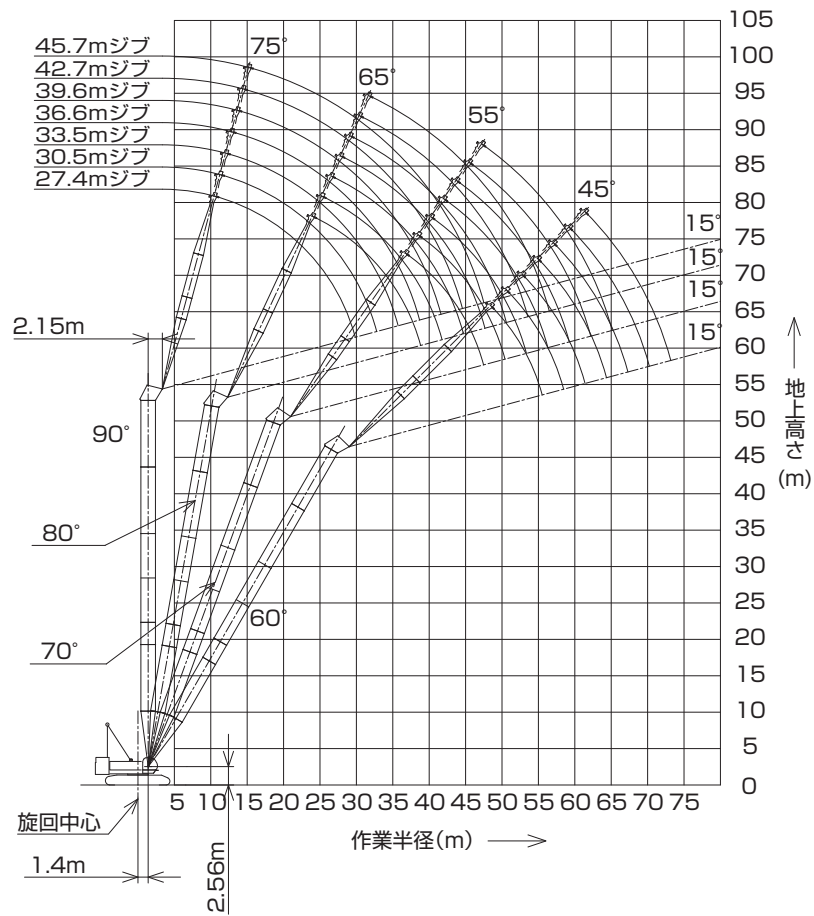

(単位:t)

タワー長さm	51.9												タワー長さm
ジブ長さm	27.4				30.5				33.5				ジブ長さm
タワー角度	90°	80°	70°	60°	90°	80°	70°	60°	90°	80°	70°	60°	タワー角度
作業半径(m)	10.0	25.0/10.9m			25.0/11.7m				25.0/12.5m				10.0
	12.0	25.0			25.0				25.0				12.0
	14.0	25.0			25.0				24.2				14.0
	16.0	25.0			25.0				23.4				16.0
	18.0	25.0			24.2				22.6				18.0
	20.0	24.2			23.5				21.8				20.0
	22.0	23.2			22.7				21.0				22.0
	24.0	20.9	20.6/24.4m		21.0	19.0/25.7m			18.8	17.8/27.0m			24.0
	26.0	18.5	18.6		18.6	18.6			16.7	16.7			26.0
	28.0	16.3	16.8		16.7	16.7			15.3	15.1			28.0
	30.0	11.3/29.9m	15.2		15.1	15.1			14.0	13.9			30.0
	32.0		14.0		12.0	13.9			12.1	12.7			32.0
	34.0		12.8		10.6/32.8m	12.7			9.2/35.8m	11.7			34.0
	36.0		11.8	11.4/37.1m		11.7			11.0	11.0			36.0
	38.0		11.1	11.1		11.0	10.7/38.9m		10.2	10.0/40.6m			38.0
	40.0		10.8/38.9m	10.4		10.3	10.3		9.6	9.5			40.0
	42.0			9.7		9.7/41.8m	9.6		8.9	8.9			42.0
	44.0			9.1			9.0		8.8/44.7m	8.4			44.0
	46.0			8.6			8.5		8.0	7.9			46.0
	48.0			8.2/47.5m	8.0/48.8m		8.0		7.5/51.0m	7.5			48.0
50.0				7.8		7.6			7.1	7.0/53.1m		50.0	
52.0				7.4		7.5/50.4m	7.3		6.9	6.8		52.0	
54.0				7.0			6.9		6.5	6.4		54.0	
56.0				6.7/55.5m			6.5		6.2	6.1		56.0	
58.0							6.2			5.8		58.0	
60.0							6.1/58.5m			5.6/61.4m		60.0	
62.0												62.0	

※表中の太線で囲まれた部分は、ブーム等の強度によって定められた値です。

200t

KOBELCO 7200G-2 クローラクレーン

yonehara

(単位:t)

タワー長さm		51.9								タワー長さm
ジブ長さm		36.6				39.6				ジブ長さm
タワー角度		90°	80°	70°	60°	90°	80°	70°	60°	タワー角度
作業半径(m)	12.0	23.9/13.3m								12.0
	14.0	23.6				22.0/14.1m				14.0
	16.0	22.9				21.4				16.0
	18.0	22.2				20.8				18.0
	20.0	21.4				20.2				20.0
	22.0	20.7				19.6				22.0
	24.0	19.9				19.0				24.0
	26.0	18.8				18.3				26.0
	28.0	16.8	16.6/28.2m			16.8	15.4/29.5m			28.0
	30.0	15.2	15.0			15.2	14.9			30.0
	32.0	14.0	13.8			14.0	13.7			32.0
	34.0	12.8	12.6			12.8	12.5			34.0
	36.0	11.6	11.6			11.8	11.5			36.0
	38.0	9.3	10.9			10.8	10.8			38.0
	40.0	8.7/38.7m	10.1			9.3	10.0			40.0
	42.0		9.5	9.3/42.4m		7.7/41.7m	9.4			42.0
	44.0		8.9	8.8			8.8	8.7/44.1m		44.0
	46.0		8.4	8.3			8.2	8.1		46.0
	48.0		7.9/47.7m	7.8			7.6	7.6		48.0
	50.0			7.4			7.2	7.2		50.0
52.0			7.0			7.1/50.6m	6.8		52.0	
54.0			6.6	6.4/55.3m			6.4		54.0	
56.0			6.3	6.3			6.1	5.9/57.4m	56.0	
58.0			6.3/56.3m	6.0			5.8	5.8	58.0	
60.0				5.7			5.6/59.3m	5.5	60.0	
62.0				5.4				5.2	62.0	
64.0				5.2				5.0	64.0	
66.0				5.1/64.4m				4.8	66.0	
68.0								4.6/67.3m	68.0	

※表中の太線で囲まれた部分は、ブーム等の強度によって定められた値です。

(単位:t)

タワー長さm		51.9								タワー長さm
ジブ長さm		42.7				45.7				ジブ長さm
タワー角度		90°	80°	70°	60°	90°	80°	70°	60°	タワー角度
作業半径(m)	14.0	20.0/14.9m				17.4/15.7m				14.0
	16.0	19.7				17.4				16.0
	18.0	19.2				16.9				18.0
	20.0	18.6				16.4				20.0
	22.0	18.1				16.0				22.0
	24.0	17.5				15.5				24.0
	26.0	17.0				15.0				26.0
	28.0	16.5				14.6				28.0
	30.0	15.2	14.4/30.8m			14.1				30.0
	32.0	14.0	13.6			13.6	13.4/32.1m			32.0
	34.0	12.8	12.4			12.6	12.3			34.0
	36.0	11.8	11.4			11.6	11.3			36.0
	38.0	10.8	10.6			10.6	10.5			38.0
	40.0	9.8	9.8			9.7	9.7			40.0
	42.0	8.9	9.2			8.9	9.0			42.0
	44.0	7.2	8.6	7.9/45.9m		8.1	8.4			44.0
	46.0	6.8/44.6m	8.0	7.9		7.1	7.8	7.4/47.6m		46.0
	48.0		7.4	7.4		6.1/47.5m	7.2	7.3		48.0
	50.0		7.0	7.0			6.8	6.8		50.0
	52.0		6.6	6.6			6.4	6.4		52.0
54.0		6.2/53.6m	6.2			6.0	6.0		54.0	
56.0			5.9			5.7	5.7		56.0	
58.0			5.6	5.3/59.6m		5.6/56.5m	5.4		58.0	
60.0			5.4	5.3			5.2	4.8/61.7m	60.0	
62.0			5.2	5.0			5.0	4.8	62.0	
64.0			5.2/62.2m	4.8			4.8	4.6	64.0	
66.0				4.6			4.6/65.2m	4.4	66.0	
68.0				4.4				4.2	68.0	
70.0				4.2				4.0	70.0	
72.0				4.2/70.2m				3.8	72.0	
74.0								3.7/73.2m	74.0	

※表中の太線で囲まれた部分は、ブーム等の強度によって定められた値です。

200t

KOBELCO 7200G-2

クローラクレーン

yonehara

▶タワー長さ 54.9m

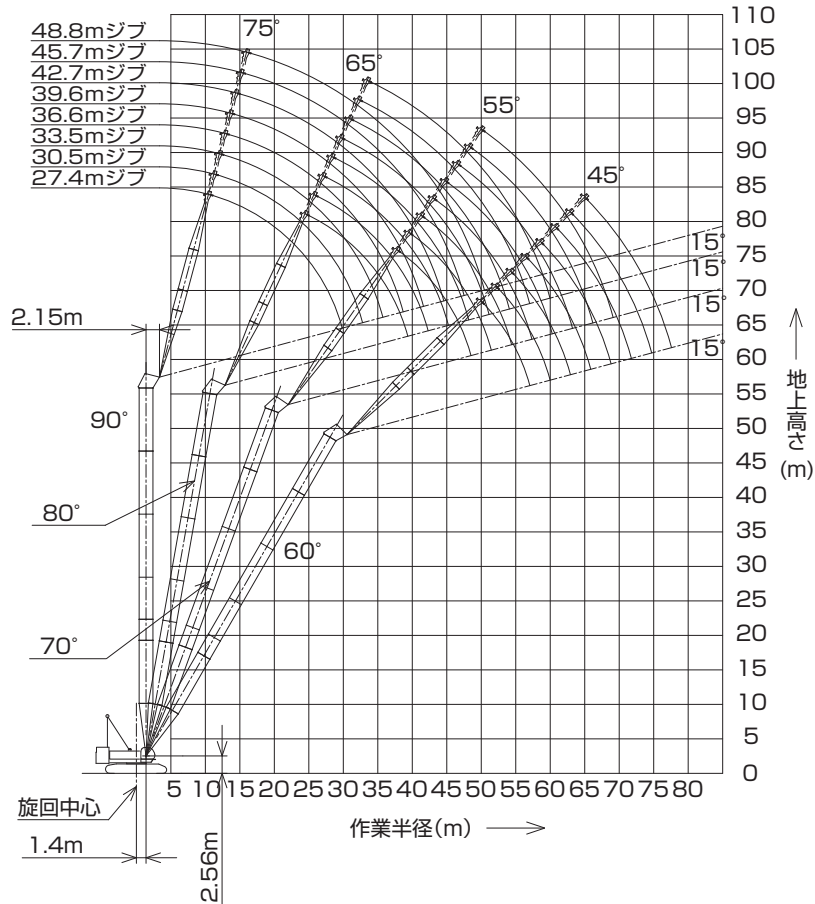

(単位:t)

タワー長さm	54.9												タワー長さm
ジブ長さm	27.4				30.5				33.5				ジブ長さm
タワー角度	90°	80°	70°	60°	90°	80°	70°	60°	90°	80°	70°	60°	タワー角度
作業半径 (m)	10.0	25.0/10.9m			25.0/11.7m								10.0
	12.0	25.0			25.0				25.0/12.5m				12.0
	14.0	25.0			25.0				25.0				14.0
	16.0	25.0			25.0				24.2				16.0
	18.0	25.0			24.2				23.4				18.0
	20.0	24.2			23.5				22.6				20.0
	22.0	23.2			22.7				21.7				22.0
	24.0	20.9	20.0/24.9m		21.0				21.0				24.0
	26.0	18.5	18.6		18.6	18.6/26.2m			18.8	17.2/27.5m			26.0
	28.0	16.3	16.8		16.7	16.7			16.7	16.7			28.0
	30.0	11.3/29.9m	15.2		15.1	15.1			15.3	15.1			30.0
	32.0		14.0		12.0	13.9			14.0	13.9			32.0
	34.0		12.8		10.6/32.8m	12.7			12.2	12.7			34.0
	36.0		11.8			11.7			9.3/35.8m	11.7			36.0
	38.0		11.1	11.0/38.2m		11.0	10.3/39.9m			11.0			38.0
	40.0		10.6/39.4m	10.4		10.3	10.3			10.2	9.6/41.7m		40.0
	42.0			9.7		9.5	9.6			9.6	9.5		42.0
	44.0			9.1		9.5/42.3m	9.0			8.9	8.9		44.0
	46.0			8.6			8.5			8.6/45.3m	8.4		46.0
	48.0			8.2			8.0				7.9		48.0
50.0			8.1/48.5m	7.7/50.3m		7.6				7.5		50.0	
52.0				7.4		7.3/51.5m	7.2/52.5m			7.1		52.0	
54.0				7.0			6.9			6.8	6.7/54.6m	54.0	
56.0				6.6			6.5			6.7/54.4m	6.4	56.0	
58.0				6.4/57.0m			6.1				6.0	58.0	
60.0							5.8/60.0m				5.7	60.0	
62.0											5.4	62.0	
64.0											5.3/62.9m	64.0	

※表中の太線で囲まれた部分は、ブーム等の強度によって定められた値です。

200t

KOBELCO 7200G-2

クローラクレーン

yonehara

(単位:t)

タワー長さm	54.9												タワー長さm
ジブ長さm	36.6				39.6				42.7				ジブ長さm
タワー角度	90°	80°	70°	60°	90°	80°	70°	60°	90°	80°	70°	60°	タワー角度
12.0	23.9/13.3m												12.0
14.0	23.6				22.0/14.1m				20.0/14.9m				14.0
16.0	22.9				21.4				19.7				16.0
18.0	22.2				20.8				19.2				18.0
20.0	21.4				20.2				18.6				20.0
22.0	20.7				19.6				18.1				22.0
24.0	19.9				19.0				17.5				24.0
26.0	18.8				18.3				17.0				26.0
28.0	16.8	16.2/28.8m			16.8				16.5				28.0
30.0	15.2	15.0			15.2	14.9/30.1m			15.2	14.1/31.4m			30.0
32.0	14.0	13.8			14.0	13.7			14.0	13.6			32.0
34.0	12.8	12.6			12.8	12.5			12.8	12.4			34.0
36.0	11.6	11.6			11.8	11.5			11.8	11.4			36.0
38.0	9.3	10.9			10.8	10.8			10.8	10.6			38.0
40.0	8.7/38.7m	10.1			9.5	10.0			9.8	9.8			40.0
42.0		9.5	9.0/43.4m		7.9/41.7m	9.4			8.8	9.2			42.0
44.0		8.9	8.8			8.8	8.3/45.2m		7.3	8.6			44.0
46.0		8.4	8.3			8.2	8.1		6.9/44.6m	8.0	7.7/46.9m		46.0
48.0		7.8	7.8			7.6	7.6			7.4	7.4		48.0
50.0		7.8/48.2m	7.4			7.2	7.2			7.0	7.0		50.0
52.0			7.0			6.9/51.2m	6.8			6.6	6.6		52.0
54.0			6.6				6.4			6.2	6.2		54.0
56.0			6.3	6.1/56.8m			6.1			6.2/54.1m	5.9		56.0
58.0			6.0/57.4m	5.9			5.8	5.7/58.9m			5.6		58.0
60.0				5.6			5.6	5.5			5.4	5.1/61.1m	60.0
62.0				5.3			5.6/60.3m	5.3			5.2	5.0	62.0
64.0				5.1				5.0			5.0/63.3m	4.8	64.0
66.0				4.9/65.9m				4.8				4.6	66.0
68.0								4.6				4.4	68.0
70.0								4.5/68.8m				4.2	70.0
72.0												4.0/71.8m	72.0

※表中の太線で囲まれた部分は、ブーム等の強度によって定められた値です。

(単位:t)

タワー長さm	54.9								タワー長さm
ジブ長さm	45.7				48.8				ジブ長さm
タワー角度	90°	80°	70°	60°	90°	80°	70°	60°	タワー角度
14.0	17.4/15.7m								14.0
16.0	17.4				15.4/16.5m				16.0
18.0	16.9				15.0				18.0
20.0	16.4				14.6				20.0
22.0	16.0				14.2				22.0
24.0	15.5				13.7				24.0
26.0	15.0				13.3				26.0
28.0	14.6				12.9				28.0
30.0	14.1				12.5				30.0
32.0	13.6	13.4/32.6m			12.0	12.1/33.9m			32.0
34.0	12.6	12.3			11.6	12.1			34.0
36.0	11.6	11.3			10.9	11.1			36.0
38.0	10.6	10.5			10.1	10.2			38.0
40.0	9.7	9.7			9.4	9.4			40.0
42.0	8.8	9.0			8.6	8.7			42.0
44.0	8.1	8.4			7.9	8.1			44.0
46.0	7.1	7.8			7.3	7.6			46.0
48.0	6.1/47.5m	7.2	7.1/48.7m		6.6	7.0			48.0
50.0		6.8	6.8		5.6	6.6	6.5/50.4m		50.0
52.0		6.4	6.4		5.3/50.5m	6.2	6.2		52.0
54.0		6.0	6.0			5.8	5.8		54.0
56.0		5.7	5.7			5.5	5.5		56.0
58.0		5.5/57.0m	5.4			5.2	5.2		58.0
60.0			5.2			5.0/60.0m	5.0		60.0
62.0			5.0	4.7/63.3m			4.8		62.0
64.0			4.8	4.6			4.6	4.3/65.4m	64.0
66.0			4.6	4.4			4.4	4.2	66.0
68.0			4.6/66.2m	4.2			4.2	4.0	68.0
70.0				4.0			4.1/69.1m	3.8	70.0
72.0				3.8				3.6	72.0
74.0				3.6				3.4	74.0
76.0				3.5/74.7m				3.2	76.0
78.0								3.0/77.7m	78.0

※表中の太線で囲まれた部分は、ブーム等の強度によって定められた値です。

▶タワー長さ 58.0m

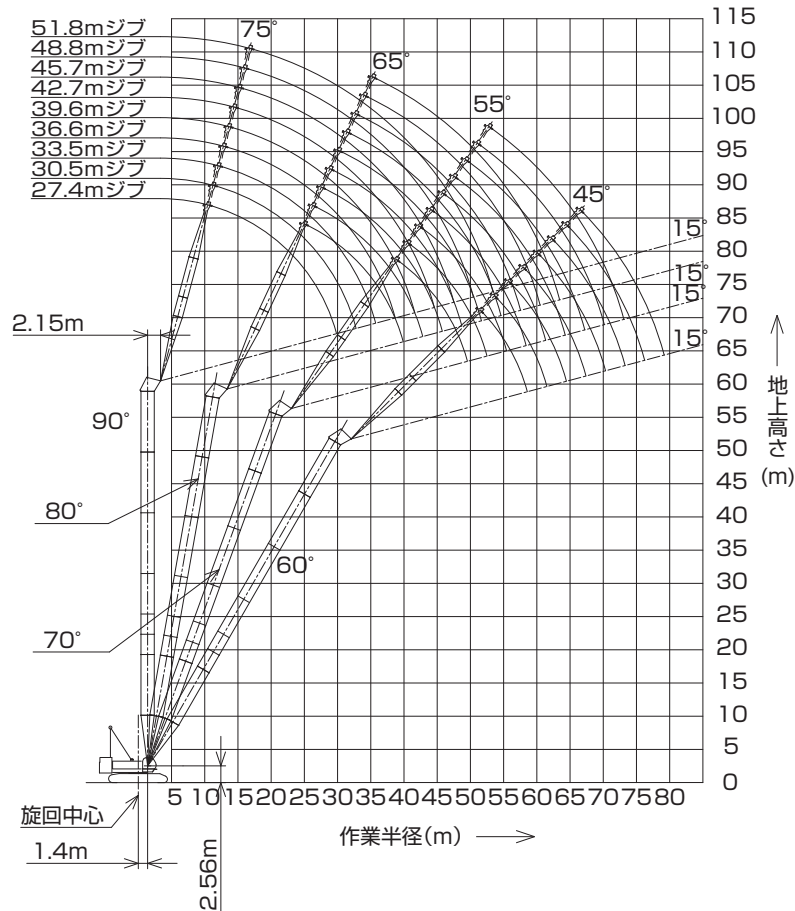

(単位:t)

タワー長さm	58.0												タワー長さm
ジブ長さm	27.4				30.5				33.5				ジブ長さm
タワー角度	90°	80°	70°	60°	90°	80°	70°	60°	90°	80°	70°	60°	タワー角度
作業半径 (m)	10.0	25.0/10.9m			25.0/11.7m								10.0
	12.0	25.0			25.0				25.0/12.5m				12.0
	14.0	25.0			25.0				25.0				14.0
	16.0	25.0			25.0				24.2				16.0
	18.0	24.9			24.2				23.4				18.0
	20.0	24.0			23.5				22.6				20.0
	22.0	23.0			22.7				21.7				22.0
	24.0	20.7	19.4/25.4m		21.0				21.0				24.0
	26.0	18.3	18.6		18.6	18.1/26.7m			18.8				26.0
	28.0	16.3	16.8		16.7	16.7			16.7	16.7/28.0m			28.0
	30.0	11.3/29.9m	15.2		15.1	15.1			15.3	15.1			30.0
	32.0		14.0		12.0	13.9			14.0	13.9			32.0
	34.0		12.8		10.6/32.8m	12.7			12.2	12.7			34.0
	36.0		11.8			11.7			9.3/35.8m	11.7			36.0
	38.0		11.1	10.6/39.7m		11.0				11.0			38.0
	40.0		10.4/39.9m	10.4		10.3	10.0/41.0m			10.2			40.0
	42.0			9.7		9.5	9.6			9.6	9.2/42.7m		42.0
	44.0			9.1		9.3/42.9m	9.0			8.9	8.9		44.0
	46.0			8.6			8.5			8.5/45.8m	8.4		46.0
	48.0			8.2			8.0				7.9		48.0
50.0			7.9/49.6m	7.4/51.8m		7.6				7.5		50.0	
52.0				7.4		7.3				7.1		52.0	
54.0				7.0		7.2/52.5m	6.9/54.0m			6.8		54.0	
56.0				6.6			6.5			6.5/55.5m	6.4/56.2m	56.0	
58.0				6.2			6.1				6.0	58.0	
60.0				6.1/58.6m			5.8				5.7	60.0	
62.0							5.6/61.5m				5.4	62.0	
64.0											5.1	64.0	
66.0											5.0/64.5m	66.0	

※表中の太線で囲まれた部分は、ブーム等の強度によって定められた値です。

200t

KOBELCO 7200G-2

クローラクレーン

yonehara

(単位:t)

タワー長さm		58.0												タワー長さm
ジブ長さm		36.6				39.6				42.7				ジブ長さm
タワー角度		90°	80°	70°	60°	90°	80°	70°	60°	90°	80°	70°	60°	タワー角度
作業半径(m)	12.0	23.9/13.3m												12.0
	14.0	23.6				22.0/14.1m				20.0/14.9m				14.0
	16.0	22.9				21.4				19.7				16.0
	18.0	22.2				20.8				19.2				18.0
	20.0	21.4				20.2				18.6				20.0
	22.0	20.7				19.6				18.1				22.0
	24.0	19.9				19.0				17.5				24.0
	26.0	18.8				18.3				17.0				26.0
	28.0	16.8	15.7/29.3m			16.8				16.5				28.0
	30.0	15.2	15.0			15.2	14.8/30.6m			15.2	13.7/31.9m			30.0
	32.0	14.0	13.8			14.0	13.7			14.0	13.6			32.0
	34.0	12.8	12.6			12.8	12.5			12.8	12.4			34.0
	36.0	11.6	11.6			11.8	11.5			11.8	11.4			36.0
	38.0	9.5	10.9			10.7	10.8			10.8	10.6			38.0
	40.0	8.9/38.7m	10.1			9.5	10.0			9.8	9.8			40.0
	42.0		9.5			7.9/41.7m	9.4			8.8	9.2			42.0
	44.0		8.9	8.7/44.5m			8.8			7.4	8.6			44.0
	46.0		8.4	8.3			8.2	8.1/46.2m		7.0/44.6m	8.0			46.0
	48.0		7.8	7.8			7.6	7.6			7.4	7.4/48.0m		48.0
	50.0		7.7/48.7m	7.4			7.2	7.2			7.0	7.0		50.0
	52.0			7.0			6.8/51.7m	6.8			6.6	6.6		52.0
	54.0			6.6				6.4			6.2	6.2		54.0
	56.0			6.3				6.1			6.1/54.6m	5.9		56.0
	58.0			6.0	5.8/58.3m			5.8				5.6		58.0
	60.0			5.9/58.4m	5.6			5.6	5.3/60.5m			5.4		60.0
	62.0				5.3			5.4/61.3m	5.1			5.2	4.8/62.6m	62.0
	64.0				5.0				4.8			4.9	4.6	64.0
	66.0				4.8				4.6			4.8/64.3m	4.4	66.0
68.0				4.6/67.4m				4.4				4.2	68.0	
70.0								4.2				4.0	70.0	
72.0								4.2/70.3m				3.8	72.0	
74.0												3.6/73.3m	74.0	

※表中の太線で囲まれた部分は、ブーム等の強度によって定められた値です。

(単位:t)

タワー長さm		58.0												タワー長さm
ジブ長さm		45.7				48.8				51.8				ジブ長さm
タワー角度		90°	80°	70°	60°	90°	80°	70°	60°	90°	80°	70°	タワー角度	
作業半径(m)	14.0	17.4/15.7m											14.0	
	16.0	17.4				15.4/16.5m				13.9/17.2m			16.0	
	18.0	16.9				15.0				13.7			18.0	
	20.0	16.4				14.6				13.3			20.0	
	22.0	16.0				14.2				12.8			22.0	
	24.0	15.5				13.7				12.4			24.0	
	26.0	15.0				13.3				12.0			26.0	
	28.0	14.6				12.9				11.6			28.0	
	30.0	14.1				12.5				11.2			30.0	
	32.0	13.6	12.7/33.2m			12.0				10.8			32.0	
	34.0	12.6	12.3			11.6	11.8/34.5m			10.4	10.6/35.7m		34.0	
	36.0	11.5	11.3			10.9	11.1			9.8	10.4		36.0	
	38.0	10.6	10.5			10.1	10.2			9.1	9.7		38.0	
	40.0	9.6	9.7			9.4	9.4			8.5	9.0		40.0	
	42.0	8.8	9.0			8.6	8.7			7.9	8.4		42.0	
	44.0	8.1	8.4			7.9	8.1			7.4	7.8		44.0	
	46.0	7.1	7.8			7.3	7.6			6.9	7.3		46.0	
	48.0	6.1/47.5m	7.2	6.9/49.7m		6.6	7.0			6.3	6.8		48.0	
	50.0		6.8	6.8		5.6	6.6	6.3/51.5m		5.9	6.4		50.0	
	52.0		6.4	6.4		5.3/50.5m	6.2	6.2		5.4	6.0	5.7/53.2m	52.0	
	54.0		6.0	6.0			5.8	5.8		4.9/53.4m	5.6	5.6	54.0	
	56.0		5.7	5.7			5.5	5.5			5.3	5.3	56.0	
	58.0		5.4/57.6m	5.4			5.2	5.2			5.0	5.0	58.0	
	60.0			5.2			5.0	5.0			4.8	4.8	60.0	
	62.0			5.0				4.9/60.5m	4.8		4.6	4.6	62.0	
	64.0			4.8	4.3/64.8m				4.6			4.3/63.5m	4.4	64.0
	66.0			4.6	4.2				4.4	3.9/66.9m			4.2	66.0
	68.0			4.4/67.2m	4.0				4.2	3.8			4.0	68.0
70.0				3.8				4.0	3.6			3.8	70.0	
72.0				3.6			4.0/70.2m	3.4				3.6	72.0	
74.0				3.4				3.2			3.5/73.1m		74.0	
76.0				3.2				3.0					76.0	
78.0				3.2/76.2m				2.8					78.0	
80.0								2.7/79.2m					80.0	

※表中の太線で囲まれた部分は、ブーム等の強度によって定められた値です。

200t

KOBELCO
クローラクレーン

7200G-2

yonehara

▶タワー長さ 61.0m

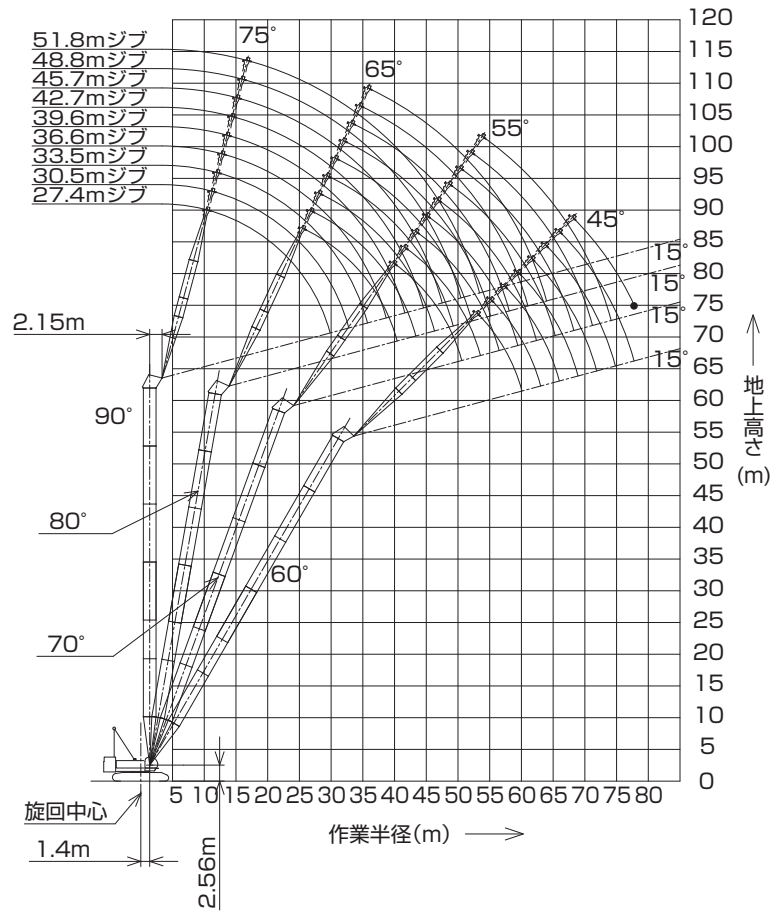

(単位:t)

タワー長さm	61.0												タワー長さm
ジブ長さm	27.4				30.5				33.5				ジブ長さm
タワー角度	90°	80°	70°	60°	90°	80°	70°	60°	90°	80°	70°	60°	タワー角度
作業半径(m)	10.0	25.0/10.9m			25.0/11.7m								10.0
	12.0	25.0			25.0				25.0/12.5m				12.0
	14.0	25.0			25.0				25.0				14.0
	16.0	24.6			24.6				24.0				16.0
	18.0	23.7			23.7				23.0				18.0
	20.0	22.9			22.7				22.0				20.0
	22.0	21.5			21.5				21.0				22.0
	24.0	20.0			20.0				20.0				24.0
	26.0	18.3	18.6/26.0m		18.6	17.4/27.3m			18.8				26.0
	28.0	16.3	16.8		16.7	16.7			16.7	16.4/28.5m			28.0
	30.0	11.3/29.9m	15.2		15.1	15.1			15.3	15.1			30.0
	32.0		14.0		12.0	13.9			14.0	13.9			32.0
	34.0		12.8		10.6/32.8m	12.7			12.3	12.7			34.0
	36.0		11.8			11.7			9.4/35.8m	11.7			36.0
	38.0		11.1			11.0				11.0			38.0
	40.0		10.4	10.3/40.3m		10.3				10.2			40.0
	42.0		10.2/40.4m	9.7		9.5	9.6/42.0m			9.6	8.8/43.8m		42.0
	44.0			9.1		9.2/43.4m	9.0			8.9	8.8		44.0
	46.0			8.6			8.5			8.4	8.4		46.0
	48.0			8.2			8.0			8.4/46.3m	7.9		48.0
50.0			7.8			7.6				7.5		50.0	
52.0			7.7/50.6m	6.8/53.4m		7.3				7.1		52.0	
54.0				6.7		6.9/53.6m	6.4/55.5m			6.7		54.0	
56.0				6.4			6.3			6.4	5.7/57.7m	56.0	
58.0				6.1			6.0			6.3/56.5m	5.7	58.0	
60.0				5.8			5.7				5.5	60.0	
62.0				5.8/60.1m			5.4				5.2	62.0	
64.0							5.2/63.0m				5.0	64.0	
66.0											4.8	66.0	
68.0											4.8/66.0m	68.0	

※表中の太線で囲まれた部分は、ブーム等の強度によって定められた値です。

200t

KOBELCO 7200G-2

クローラクレーン

yonehara

(単位:t)

タワー長さm		61.0												タワー長さm
ジブ長さm		36.6				39.6				42.7				ジブ長さm
タワー角度		90°	80°	70°	60°	90°	80°	70°	60°	90°	80°	70°	60°	タワー角度
作業半径(m)	12.0	23.9/13.3m												12.0
	14.0	23.6				22.0/14.1m				20.0/14.9m				14.0
	16.0	22.9				21.4				19.7				16.0
	18.0	22.2				20.8				19.2				18.0
	20.0	21.4				20.2				18.6				20.0
	22.0	20.7				19.6				18.1				22.0
	24.0	19.9				19.0				17.5				24.0
	26.0	18.8				18.3				17.0				26.0
	28.0	16.8	15.2/29.8m			16.8				16.5				28.0
	30.0	15.2	15.0			15.2	14.3/31.1m			15.2				30.0
	32.0	14.0	13.8			14.0	13.7			14.0	13.5/32.4m			32.0
	34.0	12.8	12.6			12.8	12.5			12.8	12.4			34.0
	36.0	11.5	11.6			11.8	11.5			11.8	11.4			36.0
	38.0	9.5	10.9			10.7	10.8			10.8	10.6			38.0
	40.0	8.9/38.7m	10.1			9.5	10.0			9.8	9.8			40.0
	42.0		9.5			7.9/41.7m	9.4			8.9	9.2			42.0
	44.0		8.9	8.4/45.5m			8.8			7.4	8.6			44.0
	46.0		8.4	8.3			8.2	7.8/47.3m		6.9/44.6m	8.0			46.0
	48.0		7.8	7.8			7.6	7.6			7.4	7.2/49.0m		48.0
	50.0		7.5/49.3m	7.4			7.2	7.2			7.0	7.0		50.0
	52.0			7.0			6.8	6.8			6.6	6.6		52.0
	54.0			6.6			6.8/52.2m	6.4			6.2	6.2		54.0
	56.0			6.3				6.1			5.9/55.2m	5.9		56.0
	58.0			6.0	5.3/59.8m			5.8				5.6		58.0
	60.0			5.8/59.4m	5.3			5.6				5.4		60.0
	62.0				5.1			5.4	4.9/62.0m			5.2		62.0
	64.0				4.9			5.3/62.4m	4.7			5.0	4.0/64.1m	64.0
	66.0				4.7				4.5			4.9/65.3m	4.0	66.0
68.0				4.4				4.2				3.8	68.0	
70.0				4.3/68.9m				3.9				3.6	70.0	
72.0								3.6				3.4	72.0	
74.0								3.6/71.9m				3.2	74.0	
76.0												3.1/74.8m	76.0	

※表中の太線で囲まれた部分は、ブーム等の強度によって定められた値です。

(単位:t)

タワー長さm		61.0												タワー長さm
ジブ長さm		45.7				48.8				51.8				ジブ長さm
タワー角度		90°	80°	70°	60°	90°	80°	70°	60°	90°	80°	70°	タワー角度	
作業半径(m)	14.0	17.4/15.7m											14.0	
	16.0	17.4				15.4/16.5m				13.9/17.2m			16.0	
	18.0	16.9				15.0				13.7			18.0	
	20.0	16.4				14.6				13.3			20.0	
	22.0	16.0				14.2				12.8			22.0	
	24.0	15.5				13.7				12.4			24.0	
	26.0	15.0				13.3				12.0			26.0	
	28.0	14.6				12.9				11.6			28.0	
	30.0	14.1				12.5				11.2			30.0	
	32.0	13.6	12.6/33.7m			12.0				10.8			32.0	
	34.0	12.6	12.3			11.6	11.4/35.0m			10.4			34.0	
	36.0	11.5	11.3			10.8	11.0			9.8	9.7/36.3m		36.0	
	38.0	10.4	10.5			9.9	10.1			9.1	9.3		38.0	
	40.0	9.5	9.7			9.3	9.3			8.5	8.7		40.0	
	42.0	8.7	9.0			8.5	8.6			7.9	8.2		42.0	
	44.0	8.1	8.4			7.8	8.0			7.4	7.6		44.0	
	46.0	7.2	7.8			7.3	7.5			6.9	7.1		46.0	
	48.0	6.2/47.5m	7.2			6.6	6.9			6.3	6.6		48.0	
	50.0		6.8	6.7/50.8m		5.6	6.5			5.8	6.2		50.0	
	52.0		6.4	6.4		5.3/50.5m	6.1	6.0/52.5m		5.3	5.8		52.0	
	54.0		6.0	6.0			5.7	5.7		4.9/53.4m	5.4	5.3/54.2m	54.0	
	56.0		5.7	5.7			5.4	5.4			5.1	5.1	56.0	
	58.0		5.4	5.4			5.1	5.1			4.8	4.8	58.0	
	60.0		5.4/58.1m	5.2			4.9	4.9			4.6	4.6	60.0	
	62.0			5.0			4.7/61.0m	4.7			4.4	4.4	62.0	
	64.0			4.8				4.5			4.1/64.0m	4.2	64.0	
	66.0			4.6	3.7/66.3m			4.3				4.0	66.0	
	68.0			4.3	3.5			4.1				3.8	68.0	
70.0			4.3/68.3m	3.3			3.9	3.1/70.0m			3.6	70.0		
72.0				3.1			3.8/71.2m	2.9			3.4	72.0		
74.0				2.9				2.7			3.2	74.0		
76.0				2.7				2.5			3.2/74.2m	76.0		
78.0				2.5/77.8m				2.3/78.0m				78.0		

※表中の太線で囲まれた部分は、ブーム等の強度によって定められた値です。

▶タワー長さ 64.1m

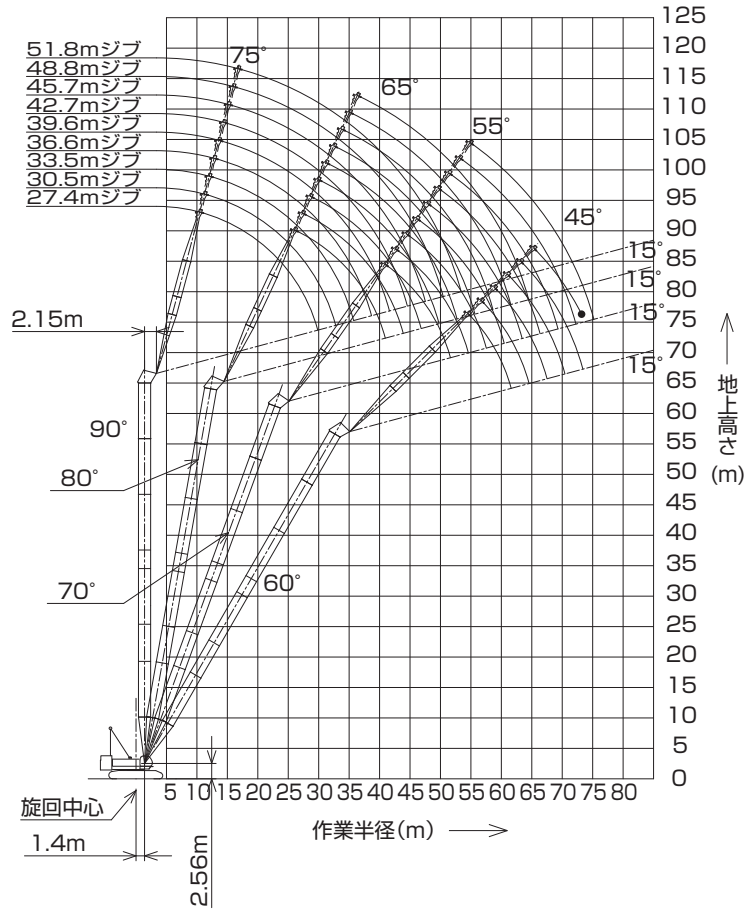

(単位:t)

タワー長さm	64.1												タワー長さm
ジブ長さm	27.4				30.5				33.5				ジブ長さm
タワー角度	90°	80°	70°	60°	90°	80°	70°	60°	90°	80°	70°	60°	タワー角度
作業半径(m)	10.0	25.0/10.9m			25.0/11.7m								10.0
	12.0	25.0			25.0				24.8/12.5m				12.0
	14.0	24.3			24.3				24.3				14.0
	16.0	23.6			23.6				23.6				16.0
	18.0	22.9			22.9				22.9				18.0
	20.0	22.2			22.2				22.0				20.0
	22.0	21.5			21.5				21.0				22.0
	24.0	20.0			20.0				20.0				24.0
	26.0	18.3	18.3/26.5m		18.6	15.9/27.8m			18.8				26.0
	28.0	16.3	16.8		16.7	16.7			16.7	15.9/29.1m			28.0
	30.0	11.3/29.9m	15.2		15.1	15.1			15.3	15.1			30.0
	32.0		14.0		12.0	13.9			14.0	13.9			32.0
	34.0		12.8		10.6/32.8m	12.7			12.3	12.7			34.0
	36.0		11.8			11.7			9.4/35.8m	11.7			36.0
	38.0		11.1			11.0				11.0			38.0
	40.0		10.4	9.9/41.3m		10.3				10.2			40.0
	42.0		10.0/41.0m	9.7		9.5	9.3/43.1m			9.6			42.0
	44.0			9.1			9.0/43.9m	9.0		8.9	8.7/44.8m		44.0
	46.0			8.6				8.5		8.4	8.4		46.0
	48.0			8.2				8.0		8.2/46.9m	7.9		48.0
50.0			7.8				7.6			7.5		50.0	
52.0			7.4/51.7m				7.3			7.1		52.0	
54.0				6.0/54.9m			6.9			6.7		54.0	
56.0				5.9		6.7/54.6m	5.4/57.1m			6.4		56.0	
58.0				5.7			5.3			6.2/57.5m	4.9/59.2m	58.0	
60.0				5.5			5.1				4.8	60.0	
62.0				5.3/61.6m			4.9				4.6	62.0	
64.0							4.7				4.4	64.0	
66.0							4.6/64.6m				4.2	66.0	
68.0											4.0/67.5m	68.0	

※表中の太線で囲まれた部分は、ブーム等の強度によって定められた値です。

200t

KOBELCO 7200G-2

クローラクレーン

yonehara

(単位:t)

タワー長さm		64.1												タワー長さm
ジブ長さm		36.6				39.6				42.7				ジブ長さm
タワー角度		90°	80°	70°	60°	90°	80°	70°	60°	90°	80°	70°	60°	タワー角度
作業半径(m)	12.0	23.9/13.3m												12.0
	14.0	23.6				22.0/14.1m				20.0/14.9m				14.0
	16.0	22.9				21.4				19.7				16.0
	18.0	22.2				20.8				19.2				18.0
	20.0	21.4				20.2				18.6				20.0
	22.0	20.7				19.6				18.1				22.0
	24.0	19.9				19.0				17.5				24.0
	26.0	18.8				18.3				17.0				26.0
	28.0	16.8				16.8				16.5				28.0
	30.0	15.2	14.9/30.4m			15.2	13.9/31.7m			15.2				30.0
	32.0	14.0	13.8			14.0	13.7			14.0	13.3/32.9m			32.0
	34.0	12.8	12.6			12.8	12.5			12.8	12.4			34.0
	36.0	11.5	11.6			11.8	11.5			11.8	11.4			36.0
	38.0	9.5	10.9			10.7	10.8			10.8	10.6			38.0
	40.0	8.9/38.7m	10.1			9.5	10.0			9.7	9.8			40.0
	42.0		9.5			7.9/41.7m	9.4			8.8	9.2			42.0
	44.0		8.9				8.8			7.4	8.6			44.0
	46.0		8.4	8.1/46.5m			8.2			6.9/44.6m	8.0			46.0
	48.0		7.8	7.8			7.6	7.6/48.3m			7.4			48.0
	50.0		7.4/49.8m	7.4			7.2	7.2			7.0	7.0/50.0m		50.0
	52.0			7.0			6.7	6.8			6.6	6.6		52.0
	54.0			6.6			6.6/52.7m	6.4			6.1	6.2		54.0
	56.0			6.3				6.1			5.8/55.7m	5.9		56.0
	58.0			6.0				5.8				5.6		58.0
	60.0			5.7	4.5/61.4m			5.6				5.4		60.0
	62.0			5.6/60.5m	4.4			5.4	4.0/63.5m			5.2		62.0
	64.0				4.2			5.3/63.4m	4.0			5.0		64.0
	66.0				4.0				3.8			4.8	3.4/66.0m	66.0
68.0				3.8				3.6			4.7/66.4m	3.4	68.0	
70.0				3.6				3.4				3.2	70.0	
72.0				3.5/70.5m				3.2				3.0	72.0	
74.0								3.0/73.4m				2.8/74.0m	74.0	

※表中の太線で囲まれた部分は、ブーム等の強度によって定められた値です。

(単位:t)

タワー長さm		64.1									タワー長さm
ジブ長さm		45.7			48.8			51.8			ジブ長さm
タワー角度		90°	80°	70°	90°	80°	70°	90°	80°	70°	タワー角度
作業半径(m)	14.0	17.4/15.7m									14.0
	16.0	17.4			15.4/16.5m			13.9/17.2m			16.0
	18.0	16.9			15.0			13.7			18.0
	20.0	16.4			14.6			13.3			20.0
	22.0	16.0			14.2			12.8			22.0
	24.0	15.5			13.7			12.4			24.0
	26.0	15.0			13.3			11.9			26.0
	28.0	14.6			12.9			11.5			28.0
	30.0	14.1			12.5			11.1			30.0
	32.0	13.6			12.0			10.8			32.0
	34.0	12.6	12.3/34.2m		11.6	11.4/35.5m		10.4			34.0
	36.0	11.5	11.3		10.8	11.0		9.8	9.2/36.8m		36.0
	38.0	10.4	10.5		9.9	10.1		9.1	9.0		38.0
	40.0	9.5	9.7		9.3	9.3		8.5	8.4		40.0
	42.0	8.7	9.0		8.5	8.6		7.9	7.9		42.0
	44.0	7.9	8.4		7.8	8.0		7.4	7.3		44.0
	46.0	7.1	7.8		7.1	7.5		6.8	6.8		46.0
	48.0	6.2/47.5m	7.2		6.4	6.9		6.2	6.3		48.0
	50.0		6.8	6.4/51.8m	5.6	6.5		5.6	5.9		50.0
	52.0		6.4	6.4	5.3/50.5m	6.1	5.8/53.5m	5.0	5.5		52.0
	54.0		6.0	6.0		5.7	5.7	4.5/53.4m	5.1	4.9/55.3m	54.0
	56.0		5.7	5.7		5.4	5.4		4.8	4.8	56.0
	58.0		5.4	5.4		5.1	5.1		4.5	4.5	58.0
	60.0		5.3/58.6m	5.2		4.9	4.9		4.3	4.3	60.0
	62.0			5.0		4.7/61.6m	4.7		4.1	4.1	62.0
	64.0			4.8			4.5		3.8	3.9	64.0
	66.0			4.6			4.3		3.7/64.5m	3.7	66.0
	68.0			4.4			4.1			3.5	68.0
70.0			4.3/69.3m			3.9			3.3	70.0	
72.0						3.8			3.1	72.0	
74.0						3.7/72.3m			3.0	74.0	
76.0									2.9/75.2m	76.0	

※表中の太線で囲まれた部分は、ブーム等の強度によって定められた値です。

200t

KOBELCO クローラクレーン

7200G-2

yonehara

▶ タワー長さ36.6m (75.1tカウンタウエイト/カーボディウエイトなし)(オプション)

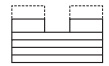

(単位:t)

タワー長さm		36.6								タワー長さm
ジブ長さm		27.4				30.5				ジブ長さm
タワー角度		90°	80°	70°	60°	90°	80°	70°	60°	タワー角度
作業半径(m)	10.0	25.0/10.9m				24.4/11.7m				10.0
	12.0	25.0				24.2				12.0
	14.0	25.0				23.8				14.0
	16.0	24.6				23.4				16.0
	18.0	24.2				23.0				18.0
	20.0	23.8	19.0/21.7m			22.6				20.0
	22.0	23.1	18.3			22.2	18.2/23.0m			22.0
	24.0	19.9	16.3			20.3	16.2			24.0
	26.0	17.1	14.8			17.7	14.7			26.0
	28.0	14.1	13.4			15.5	13.3			28.0
	30.0	10.2/29.9m	12.3	11.6/31.9m		13.4	12.2			30.0
	32.0		11.4	11.4		10.5	11.3	10.5/33.7m		32.0
	34.0		10.6	10.6		8.9/32.8m	10.5	10.4		34.0
	36.0		9.9	9.9			9.8	9.7		36.0
	38.0		8.2/36.2m	9.3			9.2	9.1		38.0
	40.0			8.8	8.5/41.2m		8.9/39.2m	8.6		40.0
	42.0			8.3	8.2			8.1	7.6/43.3m	42.0
	44.0			8.2/42.3m	7.7			7.6	7.4	44.0
	46.0				7.2			7.5/45.2m	7.0	46.0
	48.0				6.7/47.9m				6.6	48.0
50.0								6.2	50.0	
52.0								6.0/50.8m	52.0	

※表中の太線で囲まれた部分は、ブーム等の強度によって定められた値です。
ジブ長さ27.4mでの、ボールフックの使用はできません。

▶ タワー長さ39.7m (75.1tカウンタウエイト/カーボディウエイトなし)(オプション)

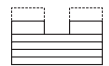

(単位:t)

タワー長さm		39.7										タワー長さm		
ジブ長さm		27.4				30.5				33.5				ジブ長さm
タワー角度		90°	80°	70°	60°	90°	80°	70°	60°	90°	80°	70°	60°	タワー角度
作業半径(m)	10.0	25.0/10.9m				24.4/11.7m								10.0
	12.0	25.0				24.2				22.7/12.5m				12.0
	14.0	25.0				23.8				22.3				14.0
	16.0	24.6				23.4				21.9				16.0
	18.0	24.2				23.0				21.5				18.0
	20.0	23.8				22.6				21.1				20.0
	22.0	23.1	18.3/22.3m			22.2	16.8/23.6m			20.7				22.0
	24.0	19.9	16.3			20.3	16.2			20.3	15.7/24.8m			24.0
	26.0	17.1	14.8			17.7	14.7			18.0	14.6			26.0
	28.0	14.1	13.4			15.5	13.3			15.9	13.2			28.0
	30.0	10.2/29.9m	12.3			13.4	12.2			14.0	12.1			30.0
	32.0		11.4	11.0/33.0m		10.5	11.3			12.3	11.2			32.0
	34.0		10.6	10.6		8.9/32.8m	10.5	10.4/34.7m		10.3	10.4			34.0
	36.0		9.9	9.9			9.8	9.7		7.8/35.8m	9.7	9.6/36.5m		36.0
	38.0		9.6/36.7m	9.3			9.2	9.1			9.1	8.9		38.0
	40.0			8.8			8.8/39.7m	8.6			8.6	8.4		40.0
	42.0			8.3	7.7/42.7m			8.1			8.1	7.9		42.0
	44.0			7.9/43.3m	7.4			7.6	7.1/44.9m		7.9/42.6m	7.4		44.0
	46.0				7.0			7.2	6.9			7.0	6.6/47.0m	46.0
	48.0				6.6			7.1/46.3m	6.5			6.6	6.4	48.0
50.0				6.3/49.4m				6.1			6.3/49.2m	6.0	50.0	
52.0								5.7				5.6	52.0	
54.0								5.6/52.4m				5.2	54.0	
56.0												4.9/55.3m	56.0	

※表中の太線で囲まれた部分は、ブーム等の強度によって定められた値です。
ジブ長さ27.4mでの、ボールフックの使用はできません。

200t

KOBELCO 7200G-2

クローラクレーン

yonehara

▶ タワー長さ42.7m (75.1tカウンタウエイト/カーボディウエイトなし)(オプション)

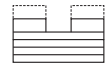

(単位:t)

タワー長さm	42.7																タワー長さm		
ジブ長さm	27.4				30.5				33.5				36.6				ジブ長さm		
タワー角度	90°	80°	70°	60°	90°	80°	70°	60°	90°	80°	70°	60°	90°	80°	70°	60°	タワー角度		
10.0	25.0/10.9m				24.4/11.7m												10.0		
12.0	25.0				24.2							22.7/12.5m				21.0/13.3m	12.0		
14.0	25.0				23.8							22.3				20.8	14.0		
16.0	24.6				23.4							21.9				20.4	16.0		
18.0	24.2				23.0							21.5				20.0	18.0		
20.0	23.8				22.6							21.1				19.6	20.0		
22.0	23.1	17.8/22.8m			22.2							20.7				19.2	22.0		
24.0	19.9	16.3			20.3	16.2/24.1m						20.3	15.2/25.4m			18.8	24.0		
26.0	17.1	14.8			17.7	14.7						18.0	14.6			18.3	26.0		
28.0	14.1	13.4			15.5	13.3						15.9	13.2			16.2	28.0		
30.0	10.2/29.9m	12.3			13.4	12.2						14.0	12.1			14.4	30.0		
32.0		11.4			10.5	11.3						12.3	11.2			12.8	32.0		
34.0		10.6	10.6		8.9/32.8m	10.5	9.8/35.8m					10.3	10.4			11.4	34.0		
36.0		9.9	9.9			9.8	9.7					7.8/35.8m	9.7			10.0	36.0		
38.0		9.5/37.3m	9.3			9.2	9.1					9.1	8.9			8.0	38.0		
40.0			8.8			8.7	8.6					8.6	8.4			6.9/38.7m	40.0		
42.0			8.3			8.6/40.2m	8.1					8.1	7.9			8.0	42.0		
44.0			7.8	7.0/44.2m			7.6					7.8/43.2m	7.4			7.5	44.0		
46.0			7.7/44.4m	6.7			7.2	6.4/46.4m				7.0				7.1	46.0		
48.0				6.4			6.9/47.3m	6.2				6.6	5.9/48.5m			7.1/46.1m	48.0		
50.0				6.1				5.9				6.2	5.7			6.0	5.3/50.7m	50.0	
52.0				5.9/51.0m				5.6					6.2/50.2m	5.4			5.7	5.2	52.0
54.0								5.3/53.9m						5.1			5.5/53.2m	4.9	54.0
56.0														4.8				4.6	56.0
58.0														4.6/56.8m				4.3	58.0
60.0																		4.0/59.8m	60.0

※表中の太線で囲まれた部分は、ブーム等の強度によって定められた値です。
ジブ長さ27.4mでの、ボールフックの使用はできません。

▶ タワー長さ45.8m (75.1tカウンタウエイト/カーボディウエイトなし)(オプション)

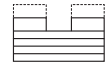

(単位:t)

タワー長さm	45.8																タワー長さm								
ジブ長さm	27.4				30.5				33.5				36.6				39.6				ジブ長さm				
タワー角度	90°	80°	70°	60°	90°	80°	70°	60°	90°	80°	70°	60°	90°	80°	70°	60°	90°	80°	70°	60°	タワー角度				
10.0	25.0/10.9m				24.4/11.7m																10.0				
12.0	25.0				24.2							22.7/12.5m					21.0/13.3m				12.0				
14.0	25.0				23.8							22.3					20.8			19.3/14.1m	14.0				
16.0	24.6				23.4							21.9					20.4			18.9	16.0				
18.0	24.2				23.0							21.5					20.0			18.5	18.0				
20.0	23.8				22.6							21.1					19.6			18.1	20.0				
22.0	23.1	17.3/23.3m			22.2							20.7					19.2			17.7	22.0				
24.0	19.9	16.3			20.3	16.0/24.6m						20.3	14.8/25.9m				18.8			17.3	24.0				
26.0	17.1	14.8			17.7	14.7						18.0	14.6				18.3	13.8/27.2m		16.9	26.0				
28.0	14.1	13.4			15.5	13.3						15.9	13.2				16.2	13.1		16.5	28.0				
30.0	10.2/29.9m	12.3			13.4	12.2						14.0	12.1				14.4	12.0		14.6	11.9	30.0			
32.0		11.4			10.5	11.3						12.3	11.2				12.8	11.1		13.0	11.0	32.0			
34.0		10.6	10.2/35.0m		8.9/32.8m	10.5						10.3	10.4				11.4	10.3		11.7	10.2	34.0			
36.0		9.9	9.9			9.8	9.5/36.8m					7.8/35.8m	9.7				10.0	9.6		10.5	9.5	36.0			
38.0		9.3/37.8m	9.3			9.2	9.1					9.1	8.5/38.5m				8.0	9.0		9.4	8.9	38.0			
40.0			8.8			8.7	8.6					8.6	8.4				6.9/38.7m	8.5	8.2/40.3m		8.0	8.4	40.0		
42.0			8.3			8.4/40.7m	8.1					8.1	7.9				8.0	7.7		6.1/41.7m	7.9	7.6	42.0		
44.0			7.8	6.6/45.8m			7.6					7.8/43.7m	7.4				7.5	7.2		7.4	7.1	44.0			
46.0			7.5/45.4m	6.5			7.2	6.1/47.9m				7.0					7.1	6.8		7.0	6.7	46.0			
48.0				6.2			6.8	6.1				6.6					7.0/46.8m	6.4		6.6	6.3	48.0			
50.0				5.9			6.7/48.3m	5.8				6.2	5.5/50.1m				6.0			6.4/48.6m	5.9		50.0		
52.0				5.6				5.5				6.0/51.3m	5.3				5.7	5.0/52.2m			5.6		52.0		
54.0				5.5/52.5m				5.2					5.0				5.5	4.8			5.4	4.6/54.4m	54.0		
56.0								4.9/55.4m					4.8				5.4/54.2m	4.6			5.1	4.4	56.0		
58.0													4.5					4.4				4.8/57.2m	4.2	58.0	
60.0													4.4/58.4m					4.2				4.0	60.0		
62.0																		4.0/61.3m					3.8	62.0	
64.0																								3.6	64.0
66.0																								3.5/64.3m	66.0

※表中の太線で囲まれた部分は、ブーム等の強度によって定められた値です。
ジブ長さ27.4mでの、ボールフックの使用はできません。

200t

KOBELCO

クローラクレーン

7200G-2

yonehara

▶ タワー長さ48.8m (75.1tカウンタウエイト/カーボディウエイトなし)(オプション)

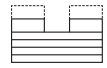

(単位:t)

タワー長さm		48.8												タワー長さm
ジブ長さm		27.4				30.5				33.5				ジブ長さm
タワー角度		90°	80°	70°	60°	90°	80°	70°	60°	90°	80°	70°	60°	タワー角度
作業半径(m)	10.0	25.0/10.9m				24.4/11.7m								10.0
	12.0	25.0				24.2				22.7/12.5m				12.0
	14.0	25.0				23.8				22.3				14.0
	16.0	24.6				23.4				21.9				16.0
	18.0	24.2				23.0				21.5				18.0
	20.0	23.8				22.6				21.1				20.0
	22.0	23.1	16.6/23.9m			22.2				20.7				22.0
	24.0	19.9	16.3			20.3	15.4/25.1m			20.3				24.0
	26.0	17.1	14.8			17.7	14.7			18.0	14.5/26.4m			26.0
	28.0	14.1	13.4			15.5	13.3			15.9	13.2			28.0
	30.0	10.2/29.9m	12.3			13.4	12.2			14.0	12.1			30.0
	32.0		11.4			10.5	11.3			12.3	11.2			32.0
	34.0		10.6			8.9/32.8m	10.5			10.3	10.4			34.0
	36.0		9.9	9.9/36.1m			9.8	9.2/37.8m		7.8/35.8m	9.7			36.0
	38.0		9.3	9.3			9.2	9.1			9.1	8.5/39.6m		38.0
	40.0		9.2/38.3m	8.8			8.7	8.6			8.6	8.4		40.0
	42.0			8.3			8.4/41.3m	8.1			8.1	7.9		42.0
	44.0			7.8				7.6			7.6	7.4		44.0
	46.0			7.4	5.9/47.3m			7.2			7.5/44.2m	7.0		46.0
	48.0			7.3/46.4m	5.9			6.8	5.3/49.4m			6.6		48.0
50.0				5.6			6.5/49.4m	5.2			6.2	5.0/51.6m	50.0	
52.0				5.3				5.0			5.9	4.9	52.0	
54.0				5.0					4.8		5.8/52.3m	4.7	54.0	
56.0								4.6				4.5	56.0	
58.0								4.5/56.9m				4.3	58.0	
60.0												4.1/59.9m	60.0	

※表中の太線で囲まれた部分は、ブーム等の強度によって定められた値です。
ジブ長さ27.4mでの、ボールフックの使用はできません。

(単位:t)

タワー長さm		48.8												タワー長さm
ジブ長さm		36.6				39.6				42.7				ジブ長さm
タワー角度		90°	80°	70°	60°	90°	80°	70°	60°	90°	80°	70°	60°	タワー角度
作業半径(m)	12.0	21.0/13.3m								17.7/14.9m				12.0
	14.0	20.8				19.3/14.1m				17.3				14.0
	16.0	20.4				18.9				16.9				16.0
	18.0	20.0				18.5				16.5				18.0
	20.0	19.6				18.1				16.1				20.0
	22.0	19.2				17.7				15.7				22.0
	24.0	18.8				17.3				15.3				24.0
	26.0	18.3	13.4/27.7m			16.9				14.9				26.0
	28.0	16.2	13.1			16.5	12.5/29.0m			14.5	11.8/30.3m			28.0
	30.0	14.4	12.0			14.6	11.9			13.1	10.9			30.0
	32.0	12.8	11.1			13.0	11.0			11.8	10.1			32.0
	34.0	11.4	10.3			11.7	10.2			10.6	9.4			34.0
	36.0	10.0	9.6			10.5	9.5			9.5	8.8			36.0
	38.0	8.0	9.0			9.4	8.9			8.6	8.3			38.0
	40.0	6.9/38.7m	8.5	7.9/41.3m		8.0	8.4			8.6	8.3			40.0
	42.0		8.0	7.7		6.1/41.7m	7.9	7.3/43.1m		7.6	7.8			42.0
	44.0		7.5	7.2			7.4	7.1		6.1	7.3	6.8/44.8m		44.0
	46.0		7.1	6.8			7.0	6.7		5.3/44.6m	6.9	6.6		46.0
	48.0		6.8/47.2m	6.4			6.6	6.3			6.5	6.2		48.0
	50.0			6.0			6.3	5.9			6.2	5.8		50.0
52.0			5.7	4.6/53.7m		6.3/50.1m	5.6			5.9	5.5		52.0	
54.0			5.5	4.6			5.4	4.3/55.9m		5.8/53.0m	5.3		54.0	
56.0			5.3/55.3m	4.4			5.1	4.3			5.0		56.0	
58.0				4.2			4.8	4.1			4.7	4.0/58.1m	58.0	
60.0				4.0			4.8/58.2m	3.9			4.5	3.8	60.0	
62.0				3.8				3.7			4.3/61.2m	3.6	62.0	
64.0				3.7/62.8m					3.5			3.4	64.0	
66.0									3.3/65.8m			3.2	66.0	
68.0												3.0	68.0	
70.0												2.9/68.7m	70.0	

※表中の太線で囲まれた部分は、ブーム等の強度によって定められた値です。

▶ タワー長さ51.9m (75.1tカウンタウエイト/カーボディウエイトなし)(オプション)

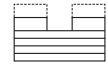

(単位:t)

タワー長さm	51.9																タワー長さm		
ジブ長さm	27.4				30.5				33.5				36.6				ジブ長さm		
タワー角度	90°	80°	70°	60°	90°	80°	70°	60°	90°	80°	70°	60°	90°	80°	70°	60°	タワー角度		
10.0	25.0/10.9m				24.4/11.7m												10.0		
12.0	25.0				24.2					22.7/12.5m					21.0/13.3m		12.0		
14.0	25.0				23.8					22.3					20.8		14.0		
16.0	24.6				23.4					21.9					20.4		16.0		
18.0	24.2				23.0					21.5					20.0		18.0		
20.0	23.8				22.6					21.1					19.6		20.0		
22.0	23.1				22.2					20.7					19.2		22.0		
24.0	19.9	16.2/24.4m			20.3	15.1/25.7m				20.3					18.8		24.0		
26.0	17.1	14.8			17.7	14.7				18.0	14.0/27.0m				18.3		26.0		
28.0	14.1	13.4			15.5	13.3				15.9	13.2				16.2	13.1/28.2m	28.0		
30.0	10.2/29.9m	12.3			13.4	12.2				14.0	12.1				14.4	12.0	30.0		
32.0		11.4			10.5	11.3				12.3	11.2				12.8	11.1	32.0		
34.0		10.6			8.9/32.8m	10.5				10.3	10.4				11.4	10.3	34.0		
36.0		9.9	9.6/37.1m			9.8				7.8/35.8m	9.7				10.0	9.6	36.0		
38.0		9.3	9.3			9.2	8.9/38.9m				9.1				8.0	9.0	38.0		
40.0		8.8/38.9m	8.8			8.7	8.6				8.6	8.3/40.6m			6.9/38.7m	8.5	40.0		
42.0			8.3			8.3/41.8m	8.1				8.1	7.9				8.0	7.9/42.4m	42.0	
44.0			7.8				7.6				7.6	7.4				7.5	7.7	44.0	
46.0			7.4				7.2				7.4/44.7m	7.0				7.1	7.2	46.0	
48.0			7.1/47.5m	5.4/48.8m			6.8					6.6				6.8/47.7m	6.8	48.0	
50.0				5.3			6.4	4.9/51.0m				6.2					6.4	50.0	
52.0				5.1			6.3/50.4m	4.8				5.9	4.5/53.1m				6.0	52.0	
54.0				4.9				4.6				5.7/53.4m	4.4				5.7	4.2/55.3m	54.0
56.0				4.7/55.5m				4.4					4.2				5.5	4.1	56.0
58.0								4.2					4.0				5.1/56.3m	3.9	58.0
60.0								4.1/58.5m										3.7	60.0
62.0																			62.0
64.0																			64.0
66.0																			66.0

※表中の太線で囲まれた部分は、ブーム等の強度によって定められた値です。
ジブ長さ27.4mでの、ボールフックの使用はできません。

(単位:t)

タワー長さm	51.9												タワー長さm
ジブ長さm	39.6				42.7				45.7				ジブ長さm
タワー角度	90°	80°	70°	60°	90°	80°	70°	60°	90°	80°	70°	60°	タワー角度
14.0	19.3/14.1m				17.7/14.9m				15.6/15.7m				14.0
16.0	18.9				17.3				15.5				16.0
18.0	18.5				16.9				15.1				18.0
20.0	18.1				16.5				14.7				20.0
22.0	17.7				16.1				14.3				22.0
24.0	17.3				15.7				13.9				24.0
26.0	16.9				15.3				13.5				26.0
28.0	16.5	12.2/29.5m			14.9				13.1				28.0
30.0	14.6	11.9			14.5	11.5/30.8m			12.7				30.0
32.0	13.0	11.0			13.1	10.9			12.3	10.8/32.1m			32.0
34.0	11.7	10.2			11.8	10.1			11.9	10.0			34.0
36.0	10.5	9.5			10.6	9.4			10.7	9.3			36.0
38.0	9.4	8.9			9.5	8.8			9.7	8.7			38.0
40.0	8.0	8.4			8.6	8.3			8.8	8.2			40.0
42.0	6.1/41.7m	7.9			7.6	7.8			7.9	7.7			42.0
44.0		7.4	7.1/44.1m		6.1	7.3	6.7/45.9m		7.1	7.2			44.0
46.0		7.0	6.7		5.3/44.6m	6.9	6.6		6.1	6.8	6.2/47.6m		46.0
48.0		6.6	6.3			6.5	6.2		4.7/47.5m	6.4	6.1		48.0
50.0		6.3	5.9			6.2	5.8			6.1	5.7		50.0
52.0		6.2/50.6m	5.6			5.9	5.5			5.8	5.5		52.0
54.0			5.4			5.7/53.6m	5.3			5.5	5.2		54.0
56.0			5.1	3.9/57.4m		5.0				5.2	4.9		56.0
58.0			4.8	3.8		4.7	3.5/59.6m			5.1/56.5m	4.6		58.0
60.0			4.6/59.3m	3.6		4.5	3.4				4.4	3.0/61.7m	60.0
62.0				3.4		4.3	3.2				4.2	3.0	62.0
64.0				3.2		4.2/62.2m	3.0				4.0	2.8	64.0
66.0				3.0			2.8				3.9/65.2m	2.6	66.0
68.0				2.7/67.3m			2.6					2.4	68.0
70.0							2.4						70.0

※表中の太線で囲まれた部分は、ブーム等の強度によって定められた値です。

200t

KOBELCO 7200G-2

クローラクレーン

yonehara

▶ タワー長さ54.9m (75.1tカウンタウエイト/カーボディウエイトなし)(オプション)

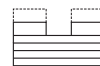

(単位:t)

タワー長さm		54.9																タワー長さm	
ジブ長さm		27.4				30.5				33.5				36.6				ジブ長さm	
タワー角度		90°	80°	70°	60°	90°	80°	70°	60°	90°	80°	70°	60°	90°	80°	70°	60°	タワー角度	
作業半径(m)	10.0	25.0/10.9m				24.4/11.7m												10.0	
	12.0	25.0				24.2				22.7/12.5m				21.0/13.3m				12.0	
	14.0	25.0				23.8				22.3				20.8				14.0	
	16.0	24.6				23.4				21.9				20.4				16.0	
	18.0	24.2				23.0				21.5				20.0				18.0	
	20.0	23.8				22.6				21.1				19.6				20.0	
	22.0	23.1				22.2				20.7				19.2				22.0	
	24.0	19.9	15.6/24.9m			20.3				20.3				18.8				24.0	
	26.0	17.1	14.8			17.7	14.7/26.2m				18.0	13.7/27.5m			18.3				26.0
	28.0	14.1	13.4			15.5	13.3				15.9	13.2			16.2	12.8/28.8m			28.0
	30.0	10.2/29.9m	12.3			13.4	12.2				14.0	12.1			14.4	12.0			30.0
	32.0		11.4			10.5	11.3				12.3	11.2			12.8	11.1			32.0
	34.0		10.6			8.9/32.8m	10.5				10.3	10.4			11.4	10.3			34.0
	36.0		9.9				9.8				7.8/35.8m	9.7			10.0	9.6			36.0
	38.0		9.3	9.3/38.2m			9.2	8.9/39.9m				9.1			8.0	9.0			38.0
	40.0		8.9/39.4m	8.8			8.7	8.6			8.6	8.0/41.7m			6.9/38.7m	8.5			40.0
	42.0			8.3			8.2	8.1			8.1	7.9				8.0	7.4/43.4m		42.0
	44.0			7.8			8.0/42.3m	7.6			7.6	7.4				7.5	7.2		44.0
	46.0			7.4				7.2			7.3/45.3m	7.0				7.1	6.8		46.0
	48.0			7.0				6.8				6.6				6.7	6.4		48.0
50.0			6.9/48.5m	5.1/50.3m			6.4				6.2				6.7/48.2m	6.0		50.0	
52.0				4.9			6.2/51.5m	4.6/52.5m			5.9					5.7		52.0	
54.0				4.7				4.4			5.7	4.2/54.6m				5.5		54.0	
56.0				4.5				4.2			5.6/54.4m	4.0			5.2	3.7/56.8m		56.0	
58.0				4.4/57.0m				4.0				3.8			5.0/57.4m	3.5		58.0	
60.0								3.8							3.5			60.0	
62.0															3.3			62.0	
64.0														3.0/62.9m				64.0	
66.0																		2.7/65.9m	66.0

※表中の太線で囲まれた部分は、ブーム等の強度によって定められた値です。
ジブ長さ27.4mでの、ボールフックの使用はできません。

(単位:t)

タワー長さm		54.9												タワー長さm	
ジブ長さm		39.6				42.7			45.7			48.8		ジブ長さm	
タワー角度		90°	80°	70°	60°	90°	80°	70°	90°	80°	70°	90°	80°	70°	タワー角度
作業半径(m)	14.0	19.3/14.1m				17.7/14.9m			15.6/15.7m						14.0
	16.0	18.9				17.3			15.5				13.8/16.5m		16.0
	18.0	18.5				16.9			15.1				13.4		18.0
	20.0	18.1				16.5			14.7				13.0		20.0
	22.0	17.7				16.1			14.3				12.6		22.0
	24.0	17.3				15.7			13.9				12.2		24.0
	26.0	16.9				15.3			13.5				11.8		26.0
	28.0	16.5				14.9			13.1				11.4		28.0
	30.0	14.6	11.9/30.1m			14.5	11.5/31.4m			12.7			11.0		30.0
	32.0	13.0	11.0			13.1	10.9			12.3	10.7/32.6m		10.6	10.0/33.9m	32.0
	34.0	11.7	10.2			11.8	10.1			11.9	10.0		10.2	9.9	34.0
	36.0	10.5	9.5			10.6	9.4			10.7	9.3		9.8	9.2	36.0
	38.0	9.4	8.9			9.5	8.8			9.7	8.7		9.4	8.6	38.0
	40.0	8.0	8.4			8.6	8.3			8.8	8.2		8.9	8.1	40.0
	42.0	6.1/41.7m	7.9			7.6	7.8			7.9	7.7		8.0	7.6	42.0
	44.0		7.4	6.9/45.2m		6.1	7.3			7.1	7.2		7.3	7.1	44.0
	46.0		7.0	6.7		5.3/44.6m	6.9	6.3/46.9m		6.1	6.8		6.6	6.7	46.0
	48.0		6.6	6.3			6.5	6.2	4.7/47.5m	6.4	6.0/48.7m		5.8	6.3	48.0
	50.0		6.3	5.9			6.2	5.8		6.1	5.7	4.7	6.0	5.6/50.4m	50.0
	52.0		6.2/51.2m	5.6			5.9	5.5		5.8	5.4	4.1/50.5m	5.7	5.3	52.0
54.0			5.4			5.6	5.3		5.5	5.2		5.4	5.0	54.0	
56.0			5.1			5.6/54.1m	5.0		5.2	4.9		5.1	4.7	56.0	
58.0			4.8	3.2/58.9m			4.7		5.0/57.0m	4.6		4.9	4.4	58.0	
60.0			4.6	3.1			4.5			4.4		4.6	4.2	60.0	
62.0			4.5/60.3m	2.9			4.3			4.2			3.9	62.0	
64.0				2.7			4.1/63.3m			4.0			3.7	64.0	
66.0				2.5						3.8			3.5	66.0	
68.0										3.7/66.2m			3.3	68.0	
70.0													3.3/69.1m	70.0	

※表中の太線で囲まれた部分は、ブーム等の強度によって定められた値です。

▶ タワー長さ58.0m (75.1tカウンタウエイト/カーボディウエイトなし)(オプション)

(単位:t)

タワー長さm		58.0															タワー長さm		
ジブ長さm		27.4				30.5				33.5			36.6			39.6			ジブ長さm
タワー角度		90°	80°	70°	60°	90°	80°	70°	60°	90°	80°	70°	90°	80°	70°	90°	80°	70°	タワー角度
作業半径(m)	10.0	25.0/10.9m				24.4/11.7m													10.0
	12.0	25.0				24.2				22.7/12.5m			21.0/13.3m						12.0
	14.0	25.0				23.8				22.3			20.8				19.3/14.1m		14.0
	16.0	24.6				23.4				21.9			20.4				18.9		16.0
	18.0	24.2				23.0				21.5			20.0				18.5		18.0
	20.0	23.8				22.6				21.1			19.6				18.1		20.0
	22.0	23.1				22.2				20.7			19.2				17.7		22.0
	24.0	19.9	15.3/25.4m			20.3				20.3			18.8				17.3		24.0
	26.0	17.1	14.8			17.7	14.4/26.7m				18.0			18.3			16.9		26.0
	28.0	14.1	13.4			15.5	13.3				15.9	13.2		16.2	12.5/29.3m		16.5		28.0
	30.0	10.2/29.9m	12.3			13.4	12.2				14.0	12.1		14.4	12.0		14.6	11.8/30.6m	30.0
	32.0		11.4			10.5	11.3				12.3	11.2		12.8	11.1		13.0	11.0	32.0
	34.0		10.6			8.9/32.8m	10.5				10.3	10.4		11.4	10.3		11.7	10.2	34.0
	36.0		9.9				9.8				7.8/35.8m	9.7		10.0	9.6		10.5	9.5	36.0
	38.0		9.3	9.0/39.2m			9.2				9.1			8.0	9.0		9.4	8.9	38.0
	40.0		8.7/39.9m	8.8			8.7	8.4/41.0m			8.6			6.9/38.7m	8.5		8.0	8.4	40.0
	42.0			8.3			8.2	8.1			8.1	7.8/42.7m		8.0			6.1/41.7m	7.9	42.0
	44.0			7.8			8.0/42.9m	7.6			7.6	7.4		7.5	7.1/44.5m		7.4		44.0
	46.0			7.4				7.2			7.1/45.8m	7.0		7.1	6.8		7.0	6.6/46.2m	46.0
	48.0			7.0				6.8				6.6		6.7	6.4		6.6	6.3	48.0
50.0			6.7/49.6m	4.4/51.8m			6.4				6.2		6.6/48.7m	6.0		6.3	5.9	50.0	
52.0				4.3			6.1				5.9			5.7		6.1/51.7m	5.6	52.0	
54.0				4.2			6.0/52.5m	3.8			5.7				5.5		5.4	54.0	
56.0				4.0				3.6			5.4/55.5m			5.2		5.1	56.0		
58.0				3.7				3.4						4.9		4.8	58.0		
60.0				3.4/58.6m				3.2						4.9/58.4m		4.6	60.0		
62.0								2.9/61.5m								4.5/61.3m	62.0		

※表中の太線で囲まれた部分は、ブーム等の強度によって定められた値です。
ジブ長さ27.4mでの、ボールフックの使用はできません。

(単位:t)

タワー長さm		58.0											タワー長さm	
ジブ長さm		42.7			45.7			48.8			51.8			ジブ長さm
タワー角度		90°	80°	70°	90°	80°	70°	90°	80°	70°	90°	80°	70°	タワー角度
作業半径(m)	14.0	17.7/14.9m			15.5/15.7m									14.0
	16.0	17.3			15.5			13.8/16.5m			11.9/17.2m			16.0
	18.0	16.9			15.1			13.4			11.8			18.0
	20.0	16.5			14.7			13.0			11.4			20.0
	22.0	16.1			14.3			12.6			11.0			22.0
	24.0	15.7			13.9			12.2			10.6			24.0
	26.0	15.3			13.5			11.8			10.2			26.0
	28.0	14.9			13.1			11.4			9.8			28.0
	30.0	14.5	11.4/31.9m			12.7			11.0			9.4		30.0
	32.0	13.1	10.9			12.3	10.4/33.2m				9.0			32.0
	34.0	11.8	10.1			11.9	10.0				10.2	9.8/34.5m		34.0
	36.0	10.6	9.4			10.7	9.3				9.8	9.2		36.0
	38.0	9.5	8.8			9.7	8.7				9.4	8.6		38.0
	40.0	8.6	8.3			8.8	8.2				8.9	8.1		40.0
	42.0	7.6	7.8			7.9	7.7				8.0	7.6		42.0
	44.0	6.1	7.3			7.1	7.2				7.3	7.1		44.0
	46.0	5.3/44.6m	6.9			6.1	6.8				6.6	6.7		46.0
	48.0		6.5	6.2		4.7/47.5m	6.4	5.8/49.7m	5.8	6.3		5.8	5.9	48.0
	50.0		6.2	5.8		6.1	5.7	4.7	6.0	5.4/51.5m	5.1	5.6		50.0
	52.0		5.9	5.5		5.8	5.4	4.1/50.5m	5.7	5.3	4.4	5.3	5.1/53.2m	52.0
54.0		5.6	5.3		5.5	5.2		5.4	5.0	3.8/53.4m	5.0	5.0	54.0	
56.0		5.5/54.6m	5.0		5.2	4.9		5.1	4.7		4.7	4.7	56.0	
58.0			4.7		5.0/57.8m	4.6		4.9	4.4		4.4	4.4	58.0	
60.0			4.5			4.4		4.6	4.2		4.2	4.2	60.0	
62.0			4.3			4.2		4.6/60.5m	3.9		4.0	4.0	62.0	
64.0			4.1			4.0			3.7		3.8/63.5m	3.8	64.0	
66.0			4.0/64.3m			3.8			3.5			3.5	66.0	
68.0						3.6/67.2m			3.3			3.3	68.0	
70.0									3.1			3.1	70.0	
72.0									3.1/70.2m			2.9	72.0	
74.0												2.5/73.1m	74.0	

※表中の太線で囲まれた部分は、ブーム等の強度によって定められた値です。

アタッチメント (オプション)

▶ クラムセル (75.1tカウンタウエイト/カーボディウエイトなし)

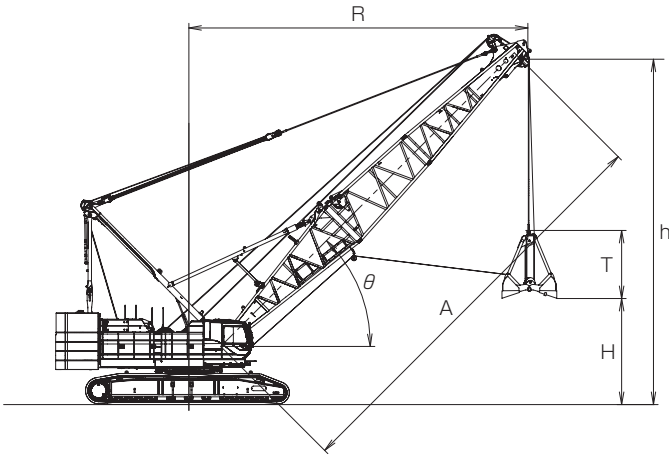

バケット 高さ 開口時	バケット 容量	2.0m ³	T	3.9m
		2.5m ³		4.3m
		3.0m ³		4.5m
		4.0m ³		4.7m

〈注〉

・バケットの単体質量は7tを超えてはいけません。

・掘削物に応じて、次式より最適なバケットをお選びください。

バケット容量(m³)×掘削物比重(t/m³)+バケット質量(t) ≤ 定格総荷重
 例)バケット容量3.0m³、掘削物砂(比重約1.5)、バケット質量5.5tの場合
 (バケット容量)×(掘削物比重)+(バケット質量) ≤ (定格総荷重)
 3.0m³ × 1.5 + 5.5t = 10.0t

ブーム長さ	m	A	18.3										21.3										
ブーム角度	度	θ	38°	43°	48°	52°	56°	60°	63°	67°	70°	36°	40°	44°	48°	51°	55°	58°	61°	64°	67°	70°	
作業半径	m	R	16.0	15.0	14.0	13.0	12.0	11.0	10.0	9.0	8.0	19.0	18.0	17.0	16.0	15.0	14.0	13.0	12.0	11.0	10.0	9.0	
開口地上高さ バケット容量	m	H	2.0m ³	6.9	8.2	9.2	10.1	10.8	11.5	12.1	12.6	13.0	8.0	9.3	10.5	11.5	12.4	13.1	13.8	14.4	15.0	15.5	15.9
			2.5m ³	6.5	7.8	8.8	9.7	10.4	11.1	11.7	12.2	12.6	7.6	8.9	10.1	11.1	12.0	12.7	13.4	14.0	14.6	15.1	15.5
			3.0m ³	6.3	7.6	8.6	9.5	10.2	10.9	11.5	12.0	12.4	7.4	8.7	9.9	10.9	11.8	12.5	13.2	13.8	14.4	14.9	15.3
			4.0m ³	6.1	7.4	8.4	9.3	10.0	10.7	11.3	11.8	12.2	7.2	8.5	9.7	10.7	11.6	12.3	13.0	13.6	14.2	14.7	15.1
ブームポイント高さ	m	h	13.5	14.8	15.8	16.7	17.4	18.1	18.7	19.2	19.6	14.6	15.9	17.1	18.1	19.0	19.7	20.4	21.0	21.6	22.1	22.5	
定格総荷重	t		12.5										12.5										

ブーム長さ	m	A	24.4													
ブーム角度	度	θ	33°	37°	41°	45°	48°	51°	54°	57°	60°	63°	65°	68°	70°	
作業半径	m	R	22.0	21.0	20.0	19.0	18.0	17.0	16.0	15.0	14.0	13.0	12.0	11.0	10.0	
開口地上高さ バケット容量	m	H	2.0m ³	9.0	10.4	11.7	12.8	13.8	14.7	15.5	16.2	16.8	17.4	17.9	18.3	18.7
			2.5m ³	8.6	10.0	11.3	12.4	13.4	14.3	15.1	15.8	16.4	17.0	17.5	17.9	18.3
			3.0m ³	8.4	9.8	11.1	12.2	13.2	14.1	14.9	15.6	16.2	16.8	17.3	17.7	18.1
			4.0m ³	8.2	9.6	10.9	12.0	13.0	13.9	14.7	15.4	16.0	16.6	17.1	17.5	17.9
ブームポイント高さ	m	h	15.6	17.0	18.3	19.4	20.4	21.3	22.1	22.8	23.4	24.0	24.5	24.9	25.3	
定格総荷重	t		12.5													

ブーム長さ	m	A	27.4														
ブーム角度	度	θ	35°	39°	42°	45°	48°	51°	54°	56°	59°	61°	63°	66°	68°	70°	
作業半径	m	R	24.0	23.0	22.0	21.0	20.0	19.0	18.0	17.0	16.0	15.0	14.0	13.0	12.0	11.0	
開口地上高さ バケット容量	m	H	2.0m ³	11.5	12.8	14.0	15.1	16.1	17.0	17.8	18.5	19.2	19.8	20.3	20.8	21.2	21.6
			2.5m ³	11.1	12.4	13.6	14.7	15.7	16.6	17.4	18.1	18.8	19.4	19.9	20.4	20.8	21.2
			3.0m ³	10.9	12.2	13.4	14.5	15.5	16.4	17.2	17.9	18.6	19.2	19.7	20.2	20.6	21.0
			4.0m ³	10.7	12.0	13.2	14.3	15.3	16.2	17.0	17.7	18.4	19.0	19.5	20.0	20.4	20.8
ブームポイント高さ	m	h	18.1	19.4	20.6	21.7	22.7	23.6	24.4	25.1	25.8	26.4	26.9	27.4	27.8	28.2	
定格総荷重	t		12.5														

ブーム長さ	m	A	30.5																
ブーム角度	度	θ	34°	37°	40°	43°	46°	48°	51°	53°	55°	58°	60°	62°	64°	66°	68°	70°	
作業半径	m	R	27.0	26.0	25.0	24.0	23.0	22.0	21.0	20.0	19.0	18.0	17.0	16.0	15.0	14.0	13.0	12.0	
開口地上高さ バケット容量	m	H	2.0m ³	12.5	13.9	15.2	16.4	17.4	18.4	19.3	20.1	20.8	21.5	22.1	22.7	23.2	23.7	24.1	24.5
			2.5m ³	12.1	13.5	14.8	16.0	17.0	18.0	18.9	19.7	20.4	21.1	21.7	22.3	22.8	23.3	23.7	24.1
			3.0m ³	11.9	13.3	14.6	15.8	16.8	17.8	18.7	19.5	20.2	20.9	21.5	22.1	22.6	23.1	23.5	23.9
			4.0m ³	11.7	13.1	14.4	15.6	16.6	17.6	18.5	19.3	20.0	20.7	21.3	21.9	22.4	22.9	23.3	23.7
ブームポイント高さ	m	h	19.1	20.5	21.8	23.0	24.0	25.0	25.9	26.7	27.4	28.1	28.7	29.3	29.8	30.3	30.7	31.1	
定格総荷重	t		12.5																

ブーム長さ	m	A	33.5																	
ブーム角度	度	θ	35°	38°	41°	43°	46°	48°	51°	53°	55°	57°	59°	61°	63°	65°	67°	69°	70°	
作業半径	m	R	29.0	28.0	27.0	26.0	25.0	24.0	23.0	22.0	21.0	20.0	19.0	18.0	17.0	16.0	15.0	14.0	13.0	
開口地上高さ バケット容量	m	H	2.0m ³	15.0	16.3	17.6	18.7	19.7	20.7	21.6	22.4	23.1	23.8	24.5	25.1	25.6	26.1	26.6	27.0	27.4
			2.5m ³	14.6	15.9	17.2	18.3	19.3	20.3	21.2	22.0	22.7	23.4	24.1	24.7	25.2	25.7	26.2	26.6	27.0
			3.0m ³	14.4	15.7	17.0	18.1	19.1	20.1	21.0	21.8	22.5	23.2	23.9	24.5	25.0	25.5	26.0	26.4	26.8
			4.0m ³	14.2	15.5	16.8	17.9	18.9	19.9	20.8	21.6	22.3	23.0	23.7	24.3	24.8	25.3	25.8	26.2	26.6
ブームポイント高さ	m	h	21.6	22.9	24.2	25.3	26.3	27.3	28.2	29.0	29.7	30.4	31.1	31.7	32.2	32.7	33.2	33.6	34.0	
定格総荷重	t		11.7	12.0	12.3															12.5

台船搭載 (オプション)

主ブーム定格総荷重表 (75.1tカウンタウエイト/カーボディウエイトなし)

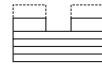

(単位 : t)

ブーム長さ 作業半径(m)	18.3	21.3	24.4	27.4	30.5	33.5	36.6	39.6	42.7	45.7	48.8	51.8	54.9	ブーム長さ 作業半径(m)
6.0	130.0	114.0/6.6m												6.0
7.0	109.0	107.2	103.0/7.3m											7.0
8.0	93.5	93.1	92.7	92.5	82.5/8.7m									8.0
9.0	82.6	82.2	81.8	81.4	81.1	75.0/9.4m								9.0
10.0	73.8	73.4	73.0	72.7	72.4	72.1	67.5/10.1m	62.0/10.7m	56.5/11.4m					10.0
12.0	58.4	60.3	59.9	59.6	59.2	58.9	58.6	58.2	55.6	52.0/12.1m	48.0/12.8m	43.8/13.5m		12.0
14.0	47.1	48.9	49.1	49.8	49.9	49.6	49.3	49.0	48.7	48.5	46.2	43.2	40.5/14.2m	14.0
16.0	38.1	40.1	40.5	41.4	42.1	42.6	42.3	42.0	41.7	41.4	40.9	40.8	38.7	16.0
18.0	30.2/17.4m	33.4	34.1	35.0	35.5	36.2	36.7	36.4	36.2	35.9	35.4	35.2	35.0	18.0
20.0		26.6	29.2	29.9	30.5	31.0	31.5	31.5	31.3	31.2	31.0	30.8	30.5	20.0
22.0		26.1/20.1m	25.3	25.9	26.5	27.0	27.4	27.6	27.4	27.2	27.0	26.8	26.6	22.0
24.0			23.1/22.7m	22.8	23.3	23.7	24.0	24.2	24.1	24.0	23.8	23.6	23.4	24.0
26.0				20.6/25.4m	20.6	21.1	21.4	21.5	21.6	21.4	21.2	21.0	20.7	26.0
28.0					18.4	18.7	19.0	19.2	19.4	19.2	19.0	18.7	18.5	28.0
30.0						16.8	17.1	17.3	17.5	17.3	17.1	16.9	16.6	30.0
32.0						16.2/30.6m	15.5	15.6	16.0	15.8	15.5	15.3	15.0	32.0
34.0							14.5/33.3m	14.2	14.5	14.3	14.1	13.9	13.7	34.0
36.0								12.9/35.9m	13.4	13.2	12.9	12.6	12.4	36.0
38.0									12.4	12.2	11.9	11.6	11.3	38.0
40.0								12.1/38.6m	11.2	10.9	10.6	10.4	10.4	40.0
42.0									10.7/41.2m	10.1	9.8	9.6	9.6	42.0
44.0										9.4/43.8m	9.0	8.8	8.8	44.0
46.0											8.4	8.1	8.1	46.0
48.0												8.3/46.5m	7.5	48.0
50.0													7.2/49.1m	50.0

※表中の太線で囲まれた部分は、ブーム等の強度によって定められた値です。

〈注〉

- ①作業半径とはクレーンの旋回中心よりつり上荷重の重心までの水平距離を意味します。
- ②定格総荷重は、フックブロック、玉掛用ワイヤロープ等のつり具の重量を含んだ値です。
- ③作業時のクレーン部の傾斜角度は、水平面に対してクレーン前後方向で3°以内、クレーン左右方向で1.5°以内となるようにしてください。定格総荷重はこの条件において設定しています。
- ④上表能力はクローラを固縛した時の能力です。
- ⑤表中の太線で囲まれた部分は、ブーム等の強度によって定められた値です。

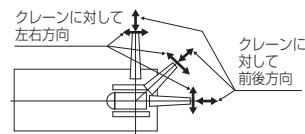

コラムセル (75.1tカウンタウエイト/カーボディウエイトなし)



(単位 : t)

ブーム長さ 作業半径(m)	18.3	21.3	24.4	27.4	30.5	33.5	ブーム長さ 作業半径(m)
9.0	12.5						9.0
10.0	12.5	12.5	12.5/11.0m				10.0
12.0	12.5	12.5	12.5	12.5	12.5/13.0m		12.0
14.0	12.5	12.5	12.5	12.5	12.5	10.0	14.0
16.0	12.5	12.5	12.5	12.5	12.5	10.0	16.0
18.0		12.5	12.5	12.5	12.5	10.0	18.0
20.0		12.5/19.0m	12.5	12.5	12.5	10.0	20.0
22.0			12.5	12.5	12.5	10.0	22.0
24.0				12.5	12.5	10.0	24.0
26.0					12.5	10.0	26.0

〈注〉

- ①バケットの単体質量は7.0tを超えてはいけません。
- ②バケットと掘削物の合計質量が定格総荷重を超えてはいけません。
- ③作業半径とは荷重状態におけるクレーンの旋回中心よりバケット重心までの水平距離を意味します。
- ④旋回時にブーム横引き荷重が作用するような急加速・急減速運転、旋回投げ捨ておよび斜め引き掘削等を行わないでください。
- ⑤作業時のクレーン部の傾斜角度は、水平面に対してクレーン前後方向で3°以内、クレーン左右方向で1.5°以内となるようにしてください。定格総荷重はこの条件において設定しています。
- ⑥上表能力はクローラを固縛した時の能力です。

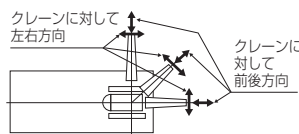

▶分解時の寸法・質量

- 記載の数値は参考値です。
- 一般公道での輸送に際しては関係法規を遵守してください。

▶本体

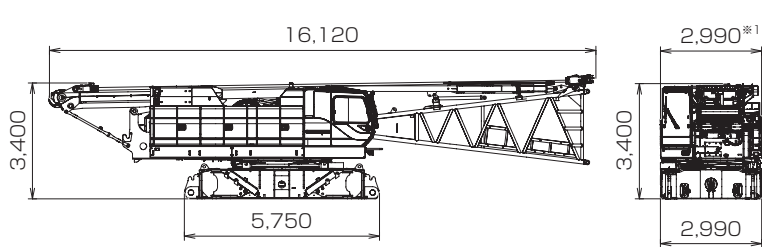
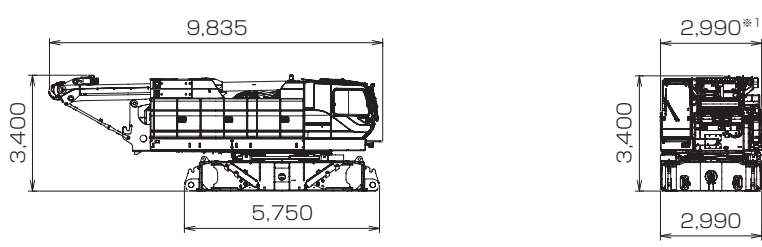
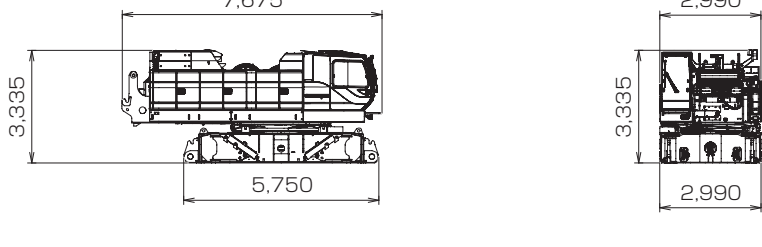
姿勢		寸法(mm)		質量 kg
ガントリー ○ 下部ブーム ○ クレーンバックストップ ○ 主巻ワイヤロープ ○ 補巻ワイヤロープ ○ ブーム起伏ワイヤロープ ○ 主巻ドラム ○ 補巻ドラム ○ 起伏ドラム ○ サイドキャットウォーク × クローラ × トランスリフタ ○ サブフレーム ○ 作動油 ○ 油圧ブームフットピン ○	○		45,850	
ガントリー ○ 下部ブーム × クレーンバックストップ × 主巻ワイヤロープ ○ 補巻ワイヤロープ ○ ブーム起伏ワイヤロープ ○ 主巻ドラム ○ 補巻ドラム ○ 起伏ドラム ○ サイドキャットウォーク × クローラ × トランスリフタ ○ サブフレーム ○ 作動油 ○ 油圧ブームフットピン ○	○		41,290	
ガントリー × 下部ブーム × クレーンバックストップ × 主巻ワイヤロープ × 補巻ワイヤロープ × ブーム起伏ワイヤロープ × 主巻ドラム ○ 補巻ドラム ○ 起伏ドラム × サイドキャットウォーク × クローラ × トランスリフタ ○ サブフレーム ○ 作動油 ○ 油圧ブームフットピン ○	○		33,150	

※1 キャブ側にサイドキャットウォークがある場合：3,170
両側にサイドキャットウォークがある場合：3,340

200t

KOBELCO 7200G-2 クローラクレーン

yonehara

○：搭載 ×：非搭載

姿勢		寸法(mm)		質量 kg
ガントリー	×			31,630
下部ブーム	×			
クレーンバックストップ	×			
主巻ワイヤロープ	×			
補巻ワイヤロープ	×			
ブーム起伏ワイヤロープ	×			
主巻ドラム	○			
補巻ドラム	○			
起伏ドラム	×			
サイドキャットウォーク	×			
クローラ	×			
トランスリフタ	×			
サブフレーム	○			
作動油	○			
油圧ブームフットピン	○			
ガントリー	×			31,870
下部ブーム	×			
クレーンバックストップ	×			
主巻ワイヤロープ	×			
補巻ワイヤロープ	○			
ブーム起伏ワイヤロープ	×			
主巻ドラム	×			
補巻ドラム	○			
起伏ドラム	×			
サイドキャットウォーク	×			
クローラ	×			
トランスリフタ	○			
サブフレーム	○			
作動油	○			
油圧ブームフットピン	○			
ガントリー	×			31,470
下部ブーム	×			
クレーンバックストップ	×			
主巻ワイヤロープ	×			
補巻ワイヤロープ	×			
ブーム起伏ワイヤロープ	×			
主巻ドラム	×			
補巻ドラム	×			
起伏ドラム	○			
サイドキャットウォーク	×			
クローラ	×			
トランスリフタ	○			
サブフレーム	○			
作動油	○			
油圧ブームフットピン	○			
ガントリー	×			27,070
下部ブーム	×			
クレーンバックストップ	×			
主巻ワイヤロープ	×			
補巻ワイヤロープ	×			
ブーム起伏ワイヤロープ	×			
主巻ドラム	×			
補巻ドラム	×			
起伏ドラム	×			
サイドキャットウォーク	×			
クローラ	×			
トランスリフタ	×			
サブフレーム	×			
作動油	×			
油圧ブームフットピン	×			

※1 キャブ側にサイドキャットウォークがある場合：3,170
両側にサイドキャットウォークがある場合：3,340

200t

KOBELCO 7200G-2

クローラクレーン

yonehara

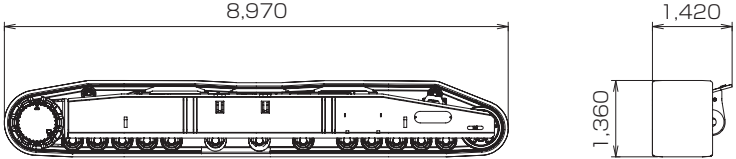
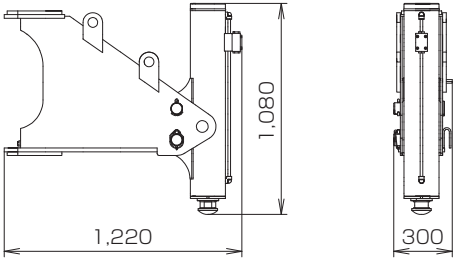
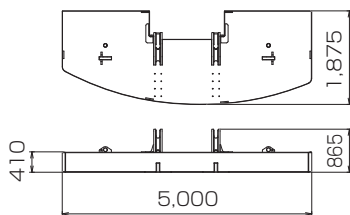
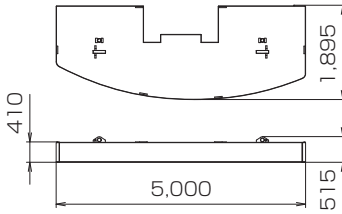
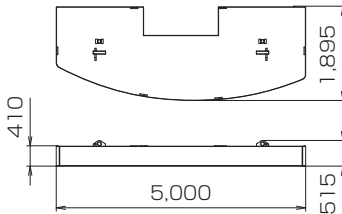
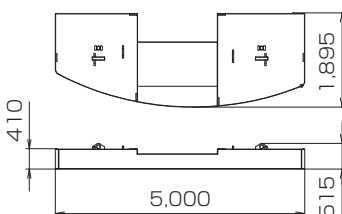
名称	寸法(mm)	質量 kg
クローラ		21,400
トランスリフタ (4個)		380/1個
カウンタウエイト (1)		13,500
カウンタウエイト (2)		13,200
カウンタウエイト (3)		13,200
カウンタウエイト (4)		13,190

200tKOBELCO
クローラクレーン

7200G-2

yonehara

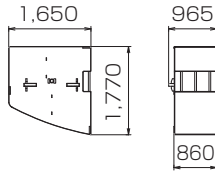
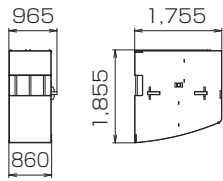
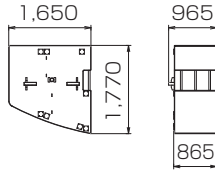
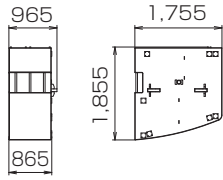
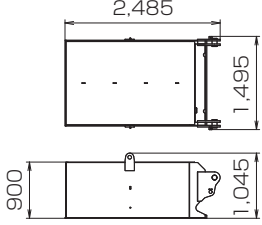
名称	寸法(mm)	質量 kg
カウンタウエイト (5)(L)		10,080
カウンタウエイト (6)(R)		11,925
カウンタウエイト (7)(L)		10,080
カウンタウエイト (8)(R)		11,925
カーボディウエイト (2個)		11,530/1個

■アタッチメント (ガイドラインの質量は含まれていません)

名称	寸法(mm)	質量 kg
上部ブーム		2,930
ロング上部ブーム 兼用 タワー上部ジブ		1,120
下部ブーム		2,960
クレーン用 バックストップ付 下部ブーム		3,860
タワー用 バックストップ付 下部ブーム		4,300
クレーン専用 バックストップ		450/1個

200t

KOBELCO クローラクレーン

7200G-2

yonehara

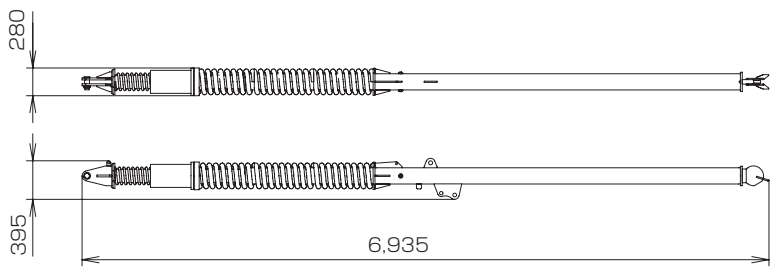
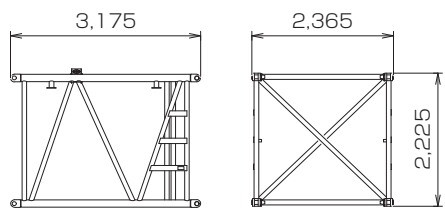
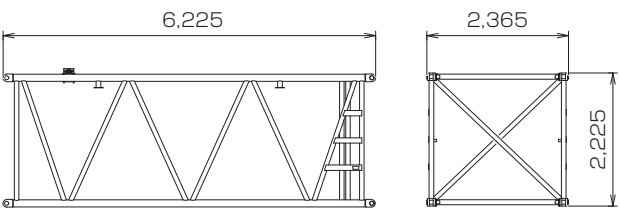
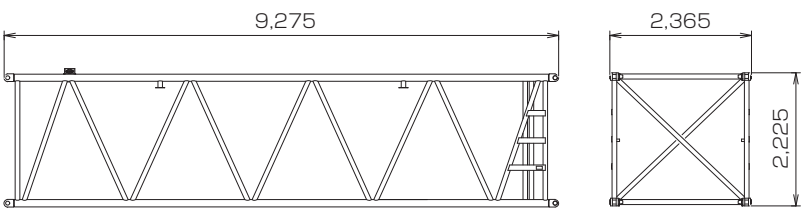
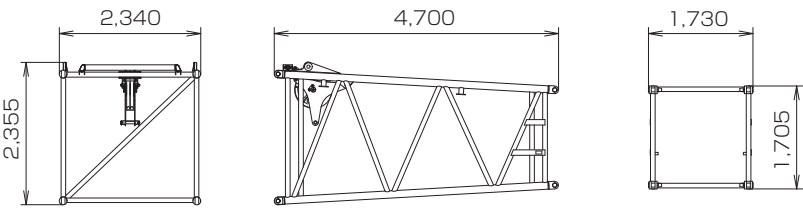
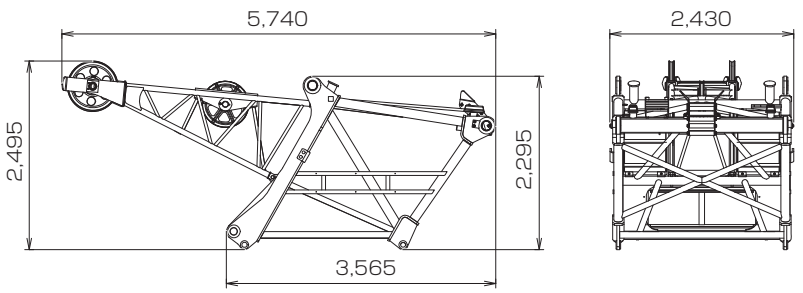
名称	寸法(mm)	質量 kg
クレーン、タワー兼用バックストップ		670/1個
3.0m中間ブーム		740
6.1m中間ブーム		1,210
9.1m中間ブーム		1,680
テーパ中間ブーム (アイドラシーブ含む)		990
ガイドローラ付 タワーキャップ		2,370

200t

KOBELCO 7200G-2

クローラクレーン

yonehara

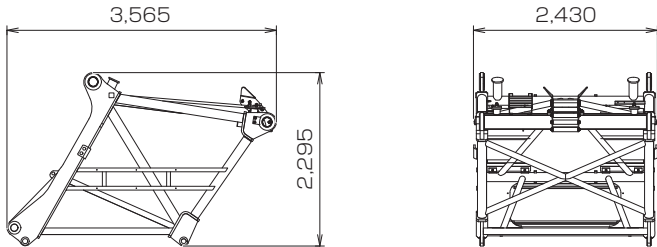
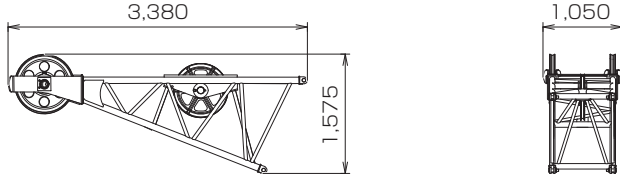
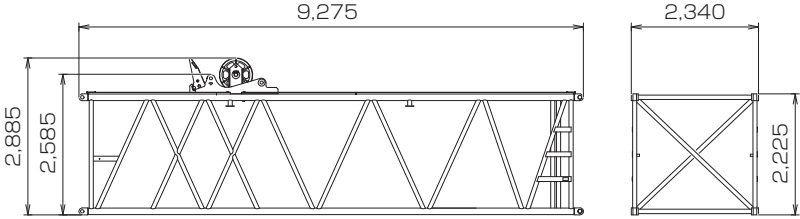
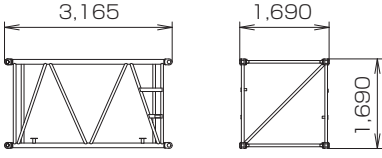
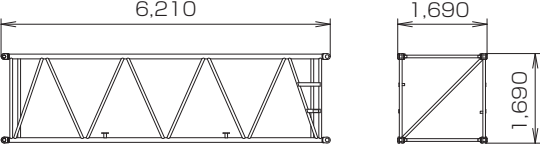
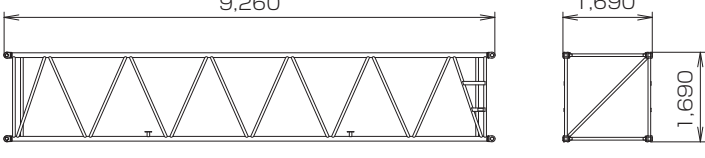
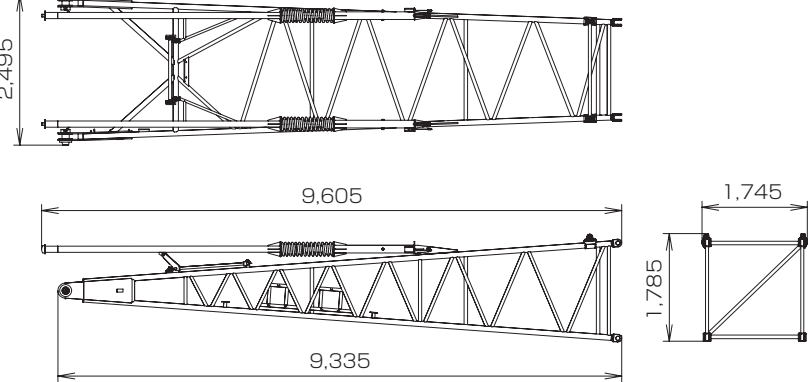
名称	寸法(mm)	質量 kg
タワーキャップ		1,850
ガイドローラ		520
9.1m特殊中間タワーブーム (サイドジブ、上面足場含む)		2,210
3.0m中間タワージブ		325
6.1m中間タワージブ		535
9.1m中間タワージブ		745
下部タワージブ		1,700

200t

KOBELCO 7200G-2 クローラクレーン

yonehara

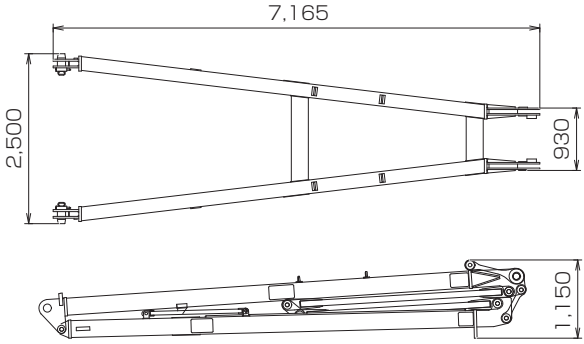
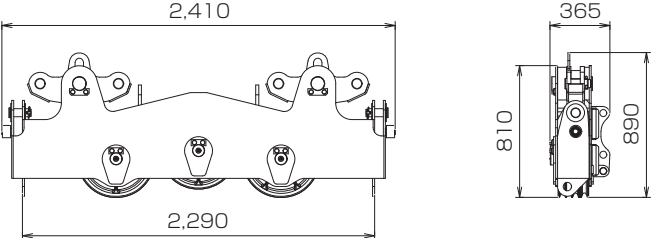
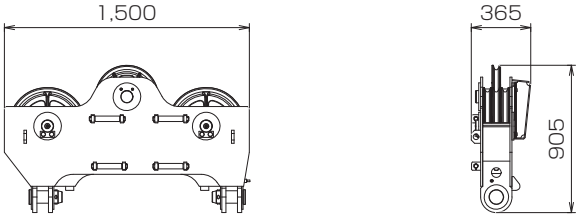
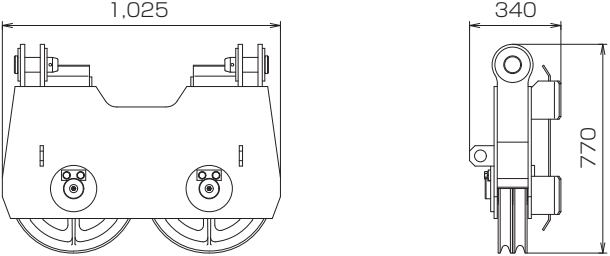
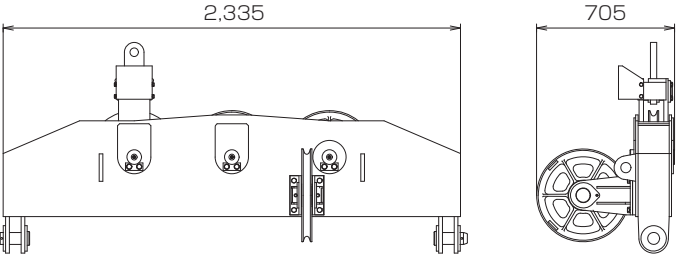
名称	寸法(mm)	質量 kg
タワージブストラット		2,170
クレーン用上部スプレッド		710
クレーン用下部スプレッド		430
タワージブ用上部スプレッド		260
タワージブ用下部スプレッド		500

200t

KOBELCO 7200G-2

クローラクレーン

yonehara

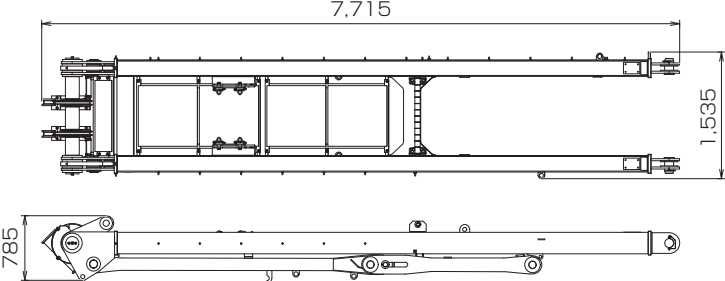
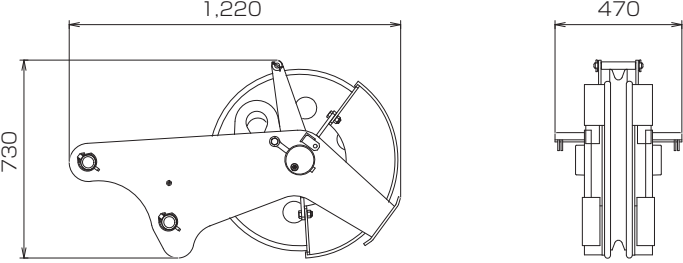
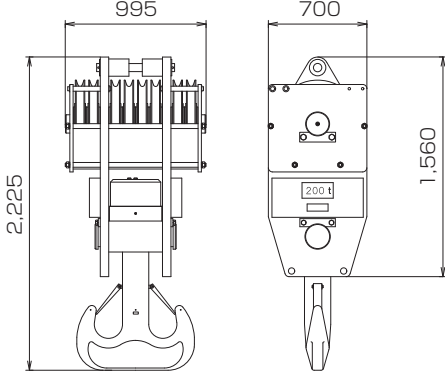
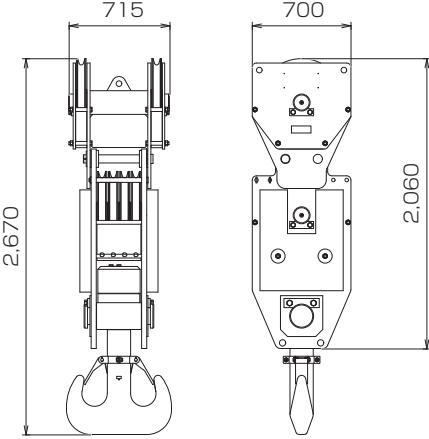
名称	寸法(mm)	質量 kg
ガントリー		3,110
補助シーブ		280
200tフック		2,800
150tフック		2,300

200t

KOBELCO 7200G-2

クローラクレーン

yonehara

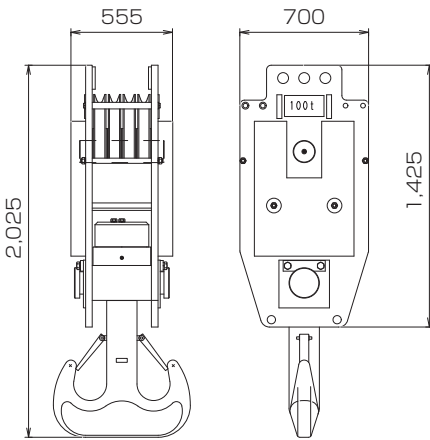
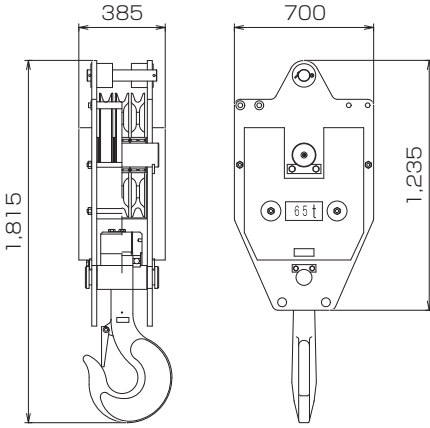
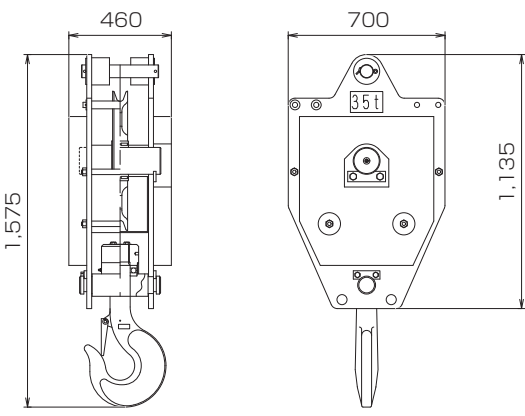
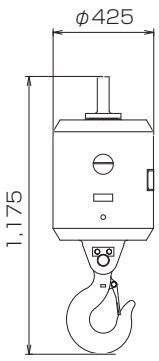
名称	寸法(mm)	質量 kg
100tフック		1,800
65tフック		1,200
35tフック		900
13.5tボールフック		455

200t

KOBELCO
クローラクレーン

7200G-2

yonehara

▶ 標準装備品

●上下部本体
ウインチ(φ28、フリーフォールなし、主巻/補巻(タワージブ起伏兼用))
カウンタウエイト97.1t
カーボディウエイト11.5t
1,070mm幅シュー
136AH/5HRバッテリー
トランスリフタ
ガントリ起伏シリンダ
電動ハンドスロットル
ブーム速度可変コントローラ
主補速度可変コントローラ
旋回中立フリー/ブレーキ切替システム
運転席サイドデッキ
サイドキャットウォーク(手すり付)
左右ガード梯子
クローラ昇降ステップ×4
アンチスリップシート(ガード上面、カウンタウエイト上面)
ブームコネクピンホルダ
上部スプレッド格納ガイド
標準工具一式
前照灯×2
バックミラー×2
ドラムミラー
ワンウェイコイル
工具箱
水準器(カーボディ)
●運転室
エアコン
カップキーパ
ラジオ(FM/AM)

シガーライタ
間欠式ワイパ&ウインドウウォッシャ(天窗/前面)
サンバイザ
天井ブラインド
グリーンガラス
フロアマット(布製)
靴置きトレイ
●安全装置
過負荷防止装置(ブーム巻下緩停止機能付)
過負荷防止装置解除防止キー
過巻防止装置解除防止キー
マルチディスプレイ
第2過巻防止装置(ブーム角度極限停止機能付)
ブーム過巻自動停止装置(緩停止機能付)
フック過巻自動停止装置
ブームバックストップ
乗降遮断式レバーロック
操作レバーロック(走行/主巻/補巻/ブーム起伏)
ケーブル式ドラムパウル(主巻/補巻/ブーム起伏)
中立時ネガブレーキ(主巻/補巻/ブーム起伏/走行)
組立分解モードスイッチ
タワージブ格納緩停止機能
旋回中立フリー/ブレーキ切替表示灯
旋回中立フリー/ブレーキ切替スイッチ
油圧安全弁(主巻/補巻/ブーム起伏/走行)
ホーン
旋回ブレーキロック
旋回ロック
旋回フラッシュ/ブザー
エンジン緊急停止スイッチ

▶ オプション装備品

トラベルキット
ウインチ(φ28、フリーフォール付、主巻/補巻(クレーン専用))
主補ウインチクイックカブラ(フリーフォールなしウインチ専用)
リーピングウインチ(ワイヤロープφ8)
油圧式タグライン
カウンタウエイト・クローラつりワイヤロープ
自立用敷板
ガイケーブル格納ブラケット
減トン仕様(カウンタウエイト枚数検出装置付)
台船搭載用ML
ブームネ스팅ローラ
フットアクセル
ブーム起伏ペダル
揚程・深度表示装置
ドラム回転感知レバー
本体傾斜計
旋回制限装置
水準器(キャブ内)
キャブ天井ガード
左右ガード上面手すり
カウンタウエイト上面手すり
定格総荷重表看板(下部ブーム腹面)
後方監視カメラ

主・補ドラム監視カメラ
ブームドラム監視カメラ
ドラムライト
過負荷外部表示灯(角型3色灯)
風速計
航空障害灯
中立フリー/過負荷ボイスアラーム
走行/旋回ボイスアラーム
電動式燃料給油ポンプ
消火器
扇風機
振り式角度計
上部ブーム腹面保護材
ブームつり用ナイロンスリング
タワーラッチ監視カメラ
ブーム上面足場(鉄/アルミ)
ブーム上面手すり(1本物/親網式)
主補コントロールレバー入替
防塵ネット(右ガード後部)
キャブ前方追加ライト
ペバスト燃焼式ヒータ
寒冷地対策オプション
キャブ左窓ガード